

WALTHER P22 BIBLE

Rev 04-17-2007



Disassembly,
Assembly, and
Functional
Improvements

Compiled from work by user
1917-1911M

at www.rimfirecentral.com

DISCLAIMER

All information is presented solely for educational and informational purposes and should not be considered as instruction in any way. The modifications may or may not be recommended to best give you the results that you are looking for. They are modifications that private individuals have experimented with and used on their own firearm. The individual contributor(s) of the modification(s) can not make any claims as to the overall safety of their modification(s) and do not accept any liability for any damage or injury caused by someone attempting it's use on their gun. Firearms are dangerous. If you misinterpret a concept expressed in this document, you may be killed or seriously injured as a result of the misunderstanding.

Whenever in doubt, consult a gunsmith of your choice before deciding on any modification.

There are no warranties, either expressed or implied, that the instructions and information in this document are accurate and reliable. There are no warranties as to fitness for a particular purpose or that this guide is merchantable. Your use of this document indicates your assumption of the risk of death or serious injury as a result of handling firearms and is an acknowledgement of your own sole responsibility for your safety.

None of these modifications are endorsed in any way by Walther or Smith and Wesson, and as such may void your firearm warranty if performed.

Revision History

Rev Date

Changes

12/21/2006

-Initial draft.

02/13/2007

-Added mod for removing .020 from bottom of breech block.

-Added disclaimer.

02/28/2007

-Added info on stove bolt replacement with longer size.

04/17/2007

-Changed document format to landscape to allow larger picture size.

PART 1

Disassembly and Assembly



WALTHER P22 BIBLE

1917-1911M



The P-22 ready for disassembly, safety on, the short barrel model without the barrel stabilizer. With exception of removal/reassembly of the stabilizer, both pistols 5" or 3.4" are the same.



Remove the magazine and any round in the chamber. Take all ammunition to another location so you can't possibly forget what you are doing while working on the pistol and no one can come along and load a round while you went for some ice tea.



After the magazines are removed and any remaining rounds removed, visually check the pistol for any rounds. If there are no magazines and no round stuck in the chamber, it is empty and unable to fire.



The next step is to pull the takedown lever down as shown in this photo, it may be easy or hard, but it will pull down this far and no more. Do this by placing thumb and finger on the lever and pull down while wiggling from side to side.



With the takedown lever down, cock the hammer, pull the slide rearward just enough so that the slide grooves clear the frame rails, then lift the rear of the slide up slightly and push the slide forward and off the end of the barrel.



This photo shows the slide off while the slide spring and guide bar are still in place. The same position they will have upon reassembly.



Next the frame would be removed from the polymer housing. In order to accomplish this, use a drift to remove the two pins that hold the frame in the housing. The front pin is slightly longer than the rear one. Reassembly is opposite. A light hammer may be necessary with a tight new gun. The more you remove and replace them the looser they get. If tightening ever becomes necessary insert a scribe in each end, tap lightly to expand the pins as required.



The frame is now free to be pulled up out of the polymer housing, however before you do place your thumb over the slide stop mechanism and the small spring that pivots it or it will fly out and that little spring is easy to loose. Some folks insert the pistol into a large baggie at this point to catch the potential flyaway part.



Your disassembled P-22 will now look like this and this is as far as the Walther Co. recommends you disassemble it. At this point there is hardly anything that you can't clean and really no reason to take the pistol apart further except to fix some broken part.



Here is a photo of the top of the pistol, slide removed showing the relationship of components of assembled pistol.



To further disassemble the frame the two "stove bolts" must be removed. These are the two that I recommend removing even w/out separating the frame halves so you can clean the threads, male and female, of all oil and then apply blue loctite to the screw threads upon reassembly. Otherwise, they will vibrate loose. I guarantee it. Note the chrome trigger pin still in place.

Note on using loctite: When loctiting the screws, only put a dab on the very end of the screw, otherwise it will be extremely difficult to remove them later. If you have trouble getting them out later, you can use a soldering iron tip to heat up the end of the screw to weaken the loctite before removal.

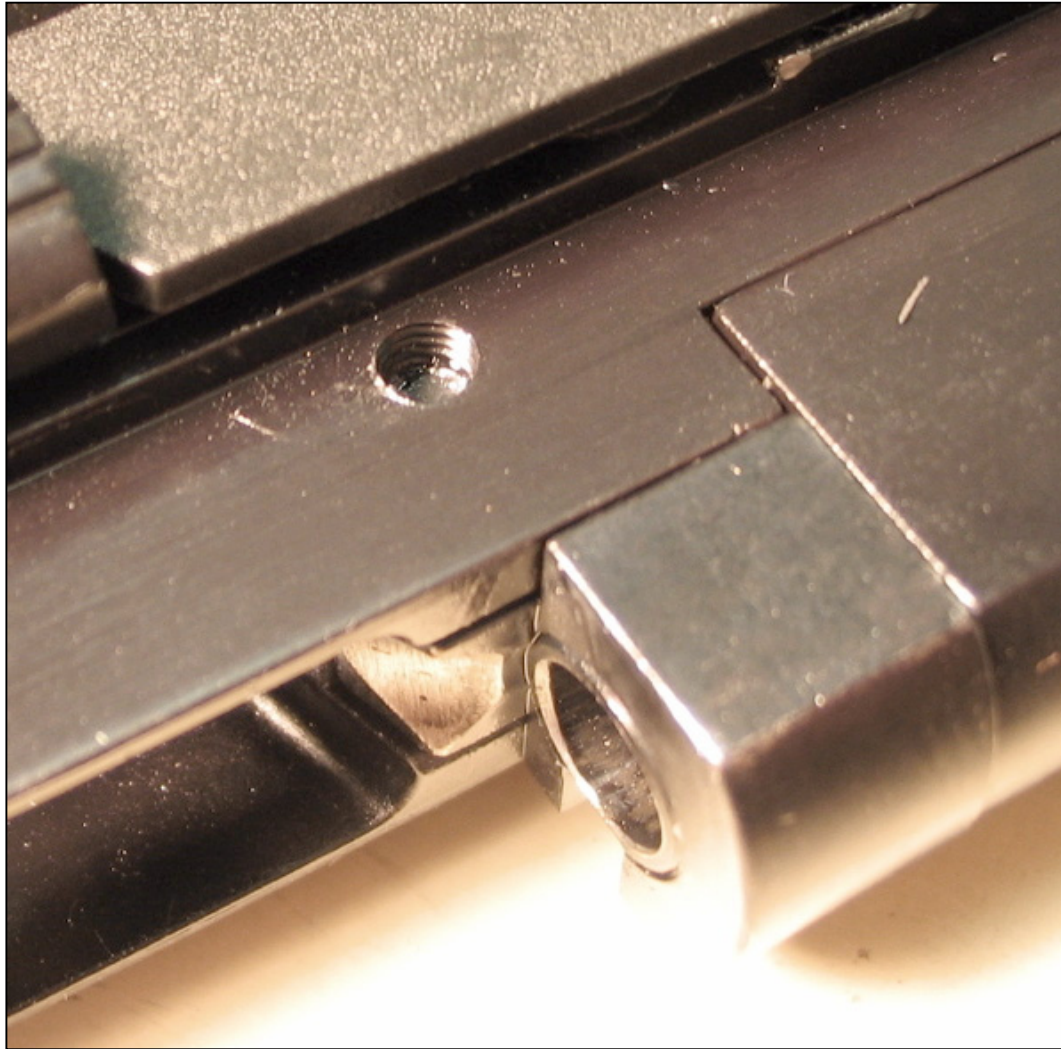

Notice also that the front frame screw (stove bolts) don't engage "all" the threads in the frame which contributes to it coming loose.

There is no length between the existing P-22 screw and the next length which is too long. Of course they are easy to cut or file off if you buy the longer one. So I installed a "full length" one. Buy a nut or two for them if you do this so that you can unscrew the nut to straighten out any slightly out of whack threads after you file them down.

M3x8 stock (get a M3x12 if you want to get all the threads) with a thread pitch of .50



With the stove bolts totally removed, use a drift to slide the trigger pin from the left side toward the right just slightly. What we are doing here is freeing the left side of the frame from this pin while allowing it to keep internal parts intact. The frame can now be separated. Wiggle the frame halves slightly while pulling apart and they will separate. The hammer pin will likely be holding the rear sides together. A little extra effort may be needed here.

You might note the barrel is still on the frame and tight. I red loctited it. It will come off but there is no reason to unless changing barrels. I only have one barrel. The only comment I have regarding removal of the barrel is to make sure it is properly aligned and seated before sliding on the barrel sleeve and barrel nut which should then be tightened with either blue or red loctite.

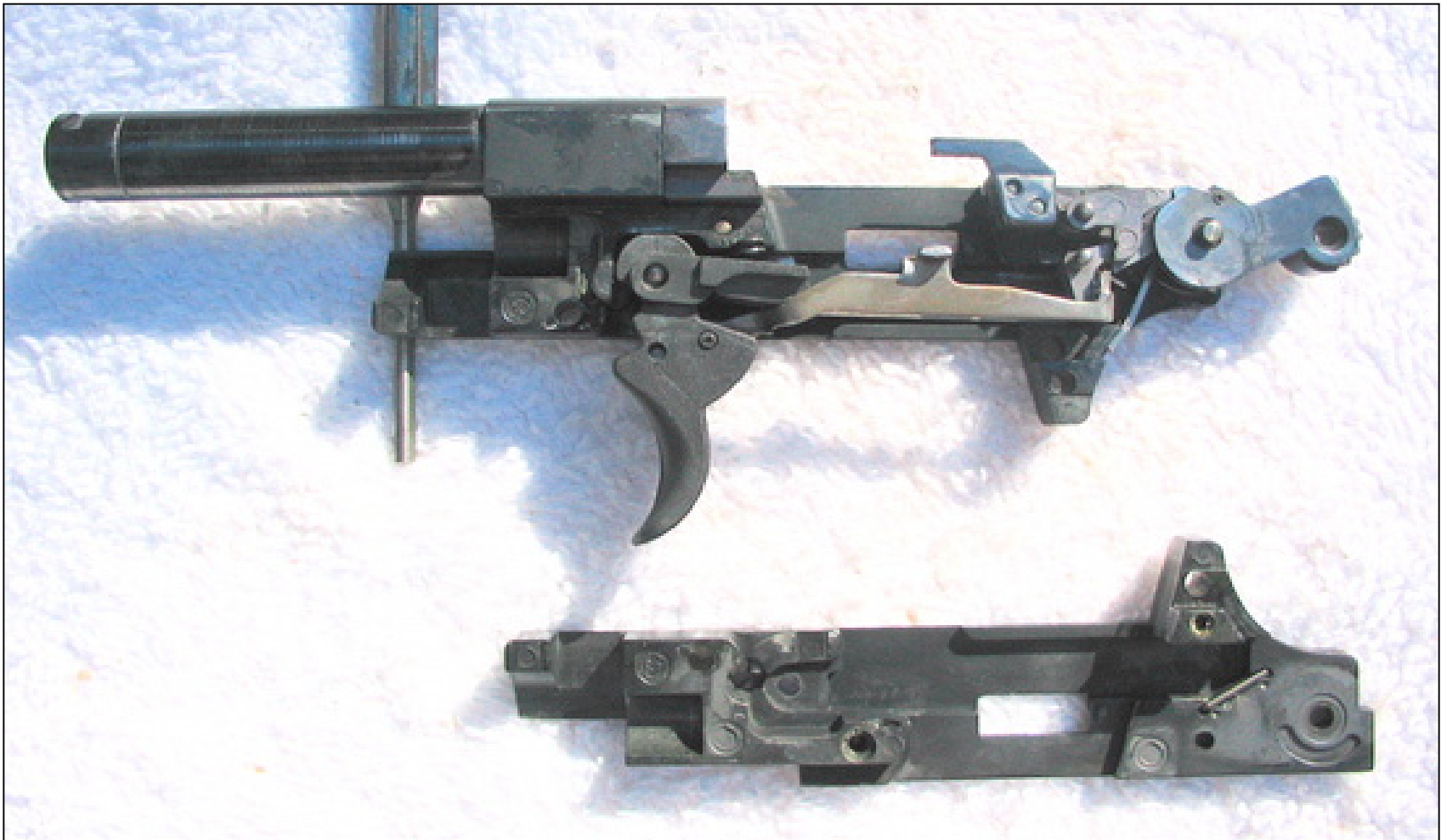

Your pistol's frame halves and internals will now look like this.

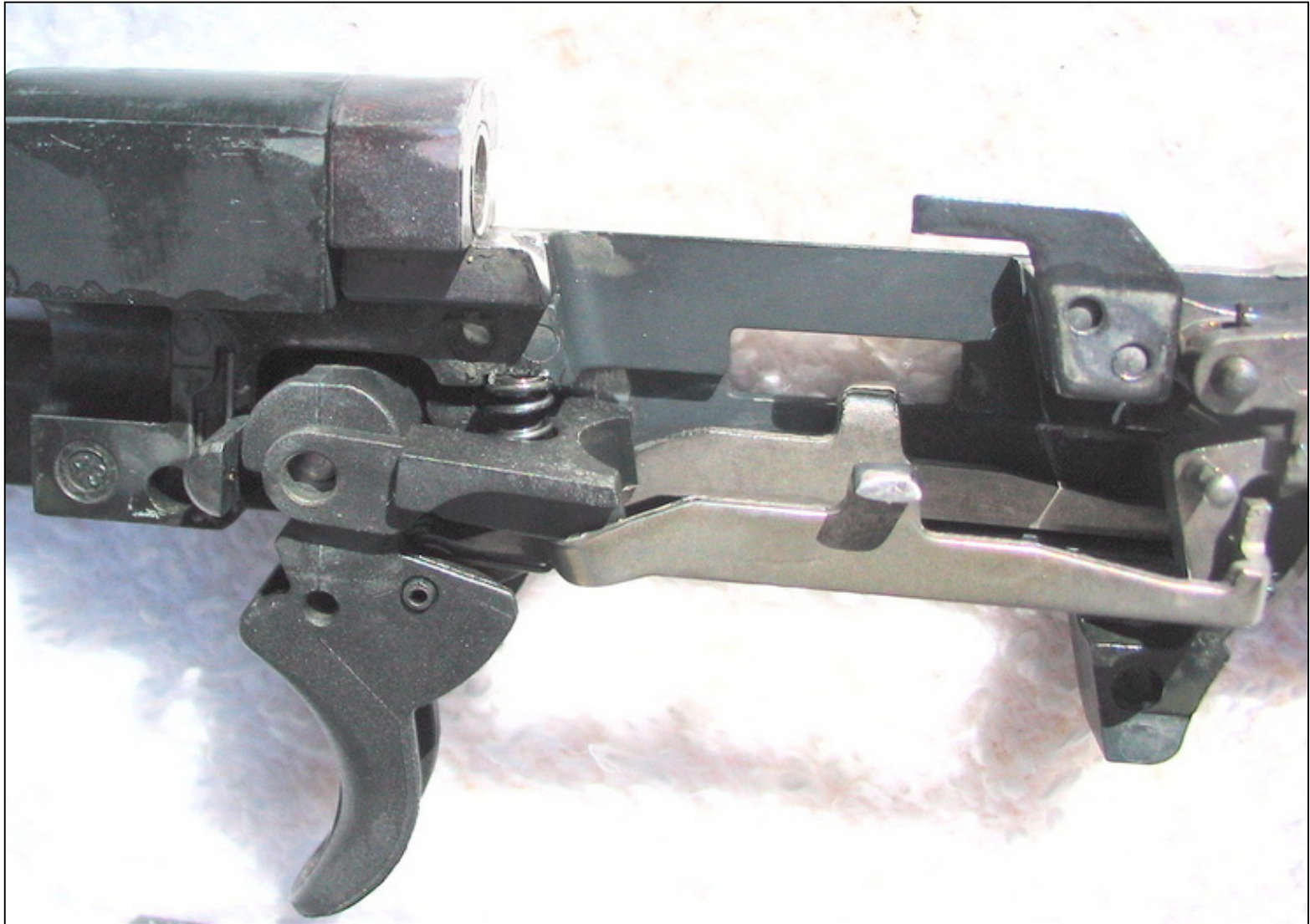

Close up of parts relationships, note rounded disconnect ears, the double spring in it's proper place for reassembly also. The trigger pin has moved slightly too much to the right, no problem but it is allowing parts to get slightly out of alignment. Note position of internal safety. Note position of trigger bar at rear engagement of trigger components. Ejector in place also. Upon assembly it is not tight. Fits over two pins.

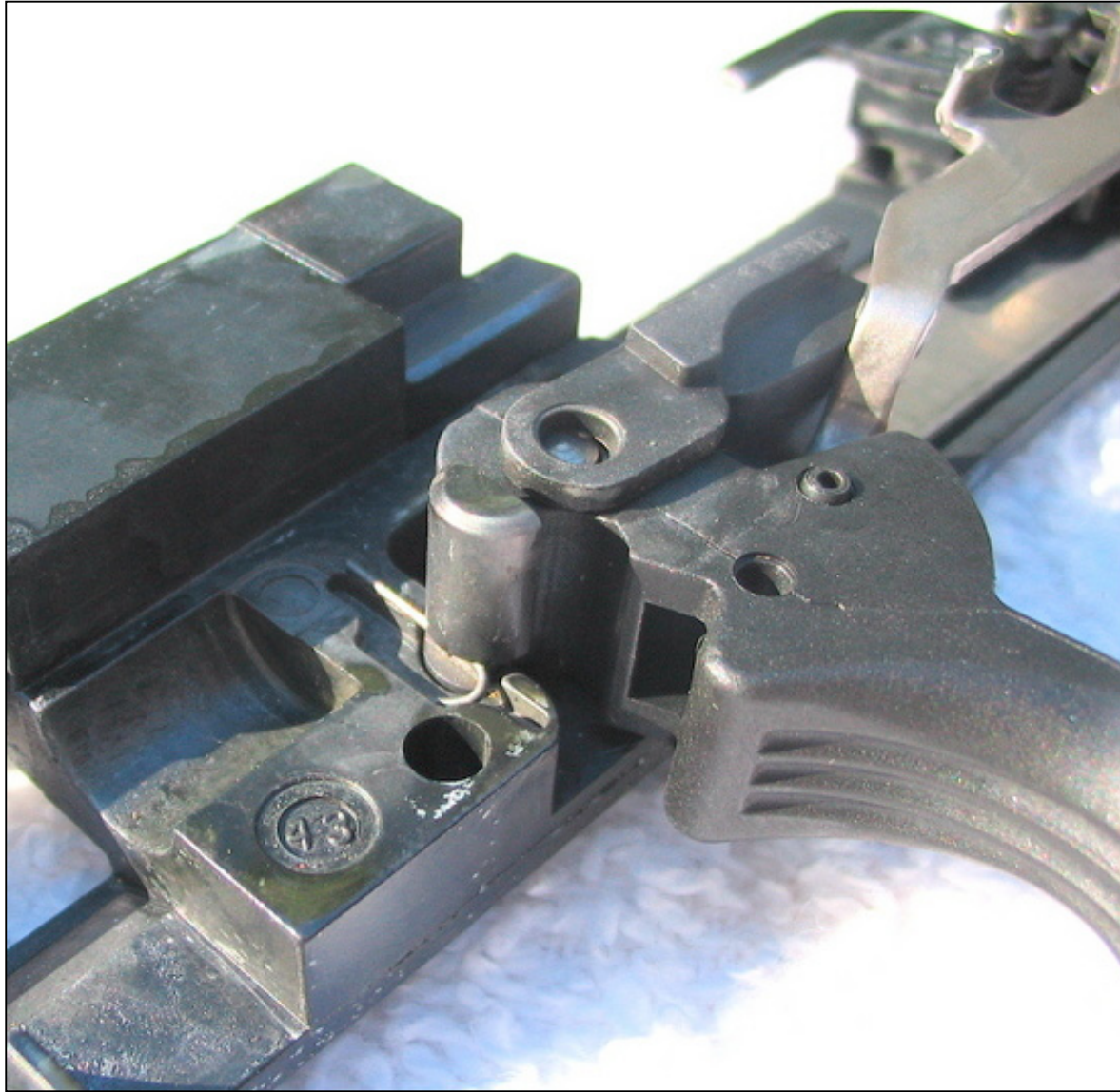

Another photo of internal component relationships. Note internal safety and spring relationship. The small pin through the trigger holds the trigger bar and trigger spring in place. No reason to take apart unless something is broken.



Relationship of components, assembled. Notice the fit of the hammer pin as it sits through the hammer. It must fit like this upon reassembly.

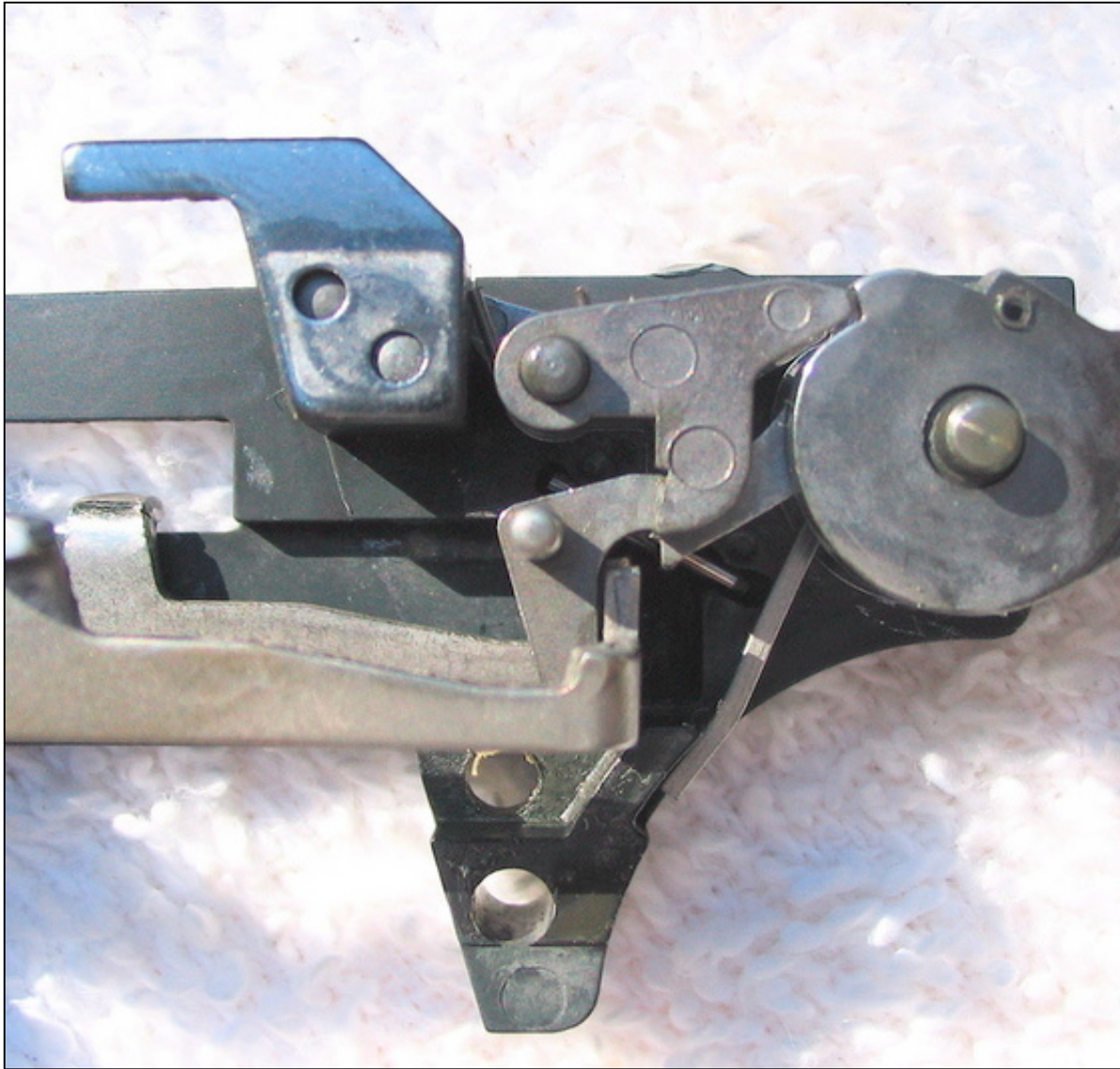

Note hammer is still cocked. Before disassembly of the hammer/sear assembly, pull the hammer rearward slightly, press down on the front of the sear arm, here hidden by the ejector, this will relieve pressure on the hammer so it can be let forward under the control of your thumb. This takes the pressure off all these parts and allows removal/reassembly.

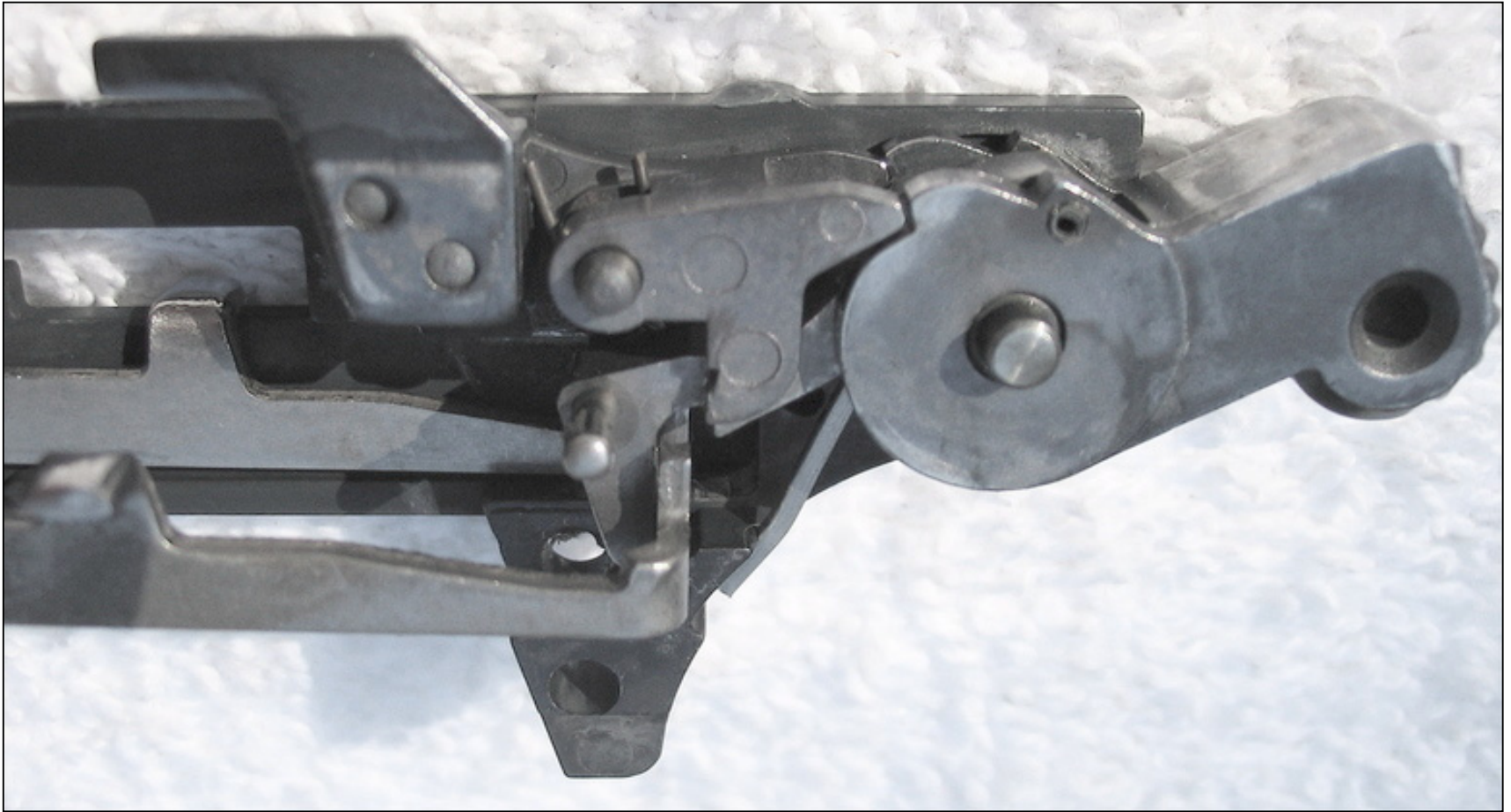

Note position of sear spring and the hammer spring. Both properly assembled.

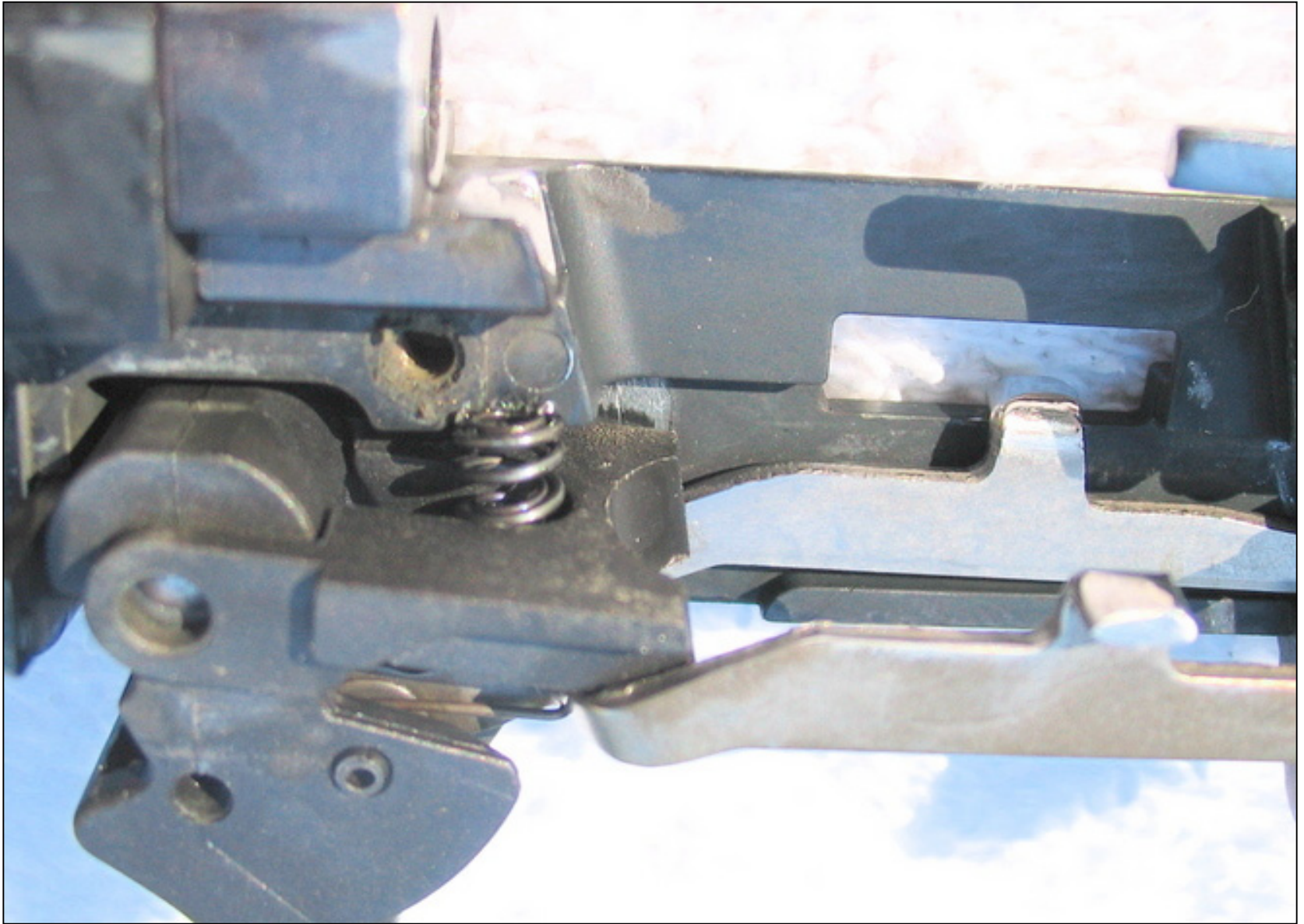

Close up of components to show proper relationship..



Trigger assembly off frame just to show relationship of components, ejector off also. To remove the trigger and trigger bar assy, half cock the hammer, pull the chrome trigger pin, rotate the components out to the left side freeing the end of the trigger bar in the process. Reassembly is just the opposite.

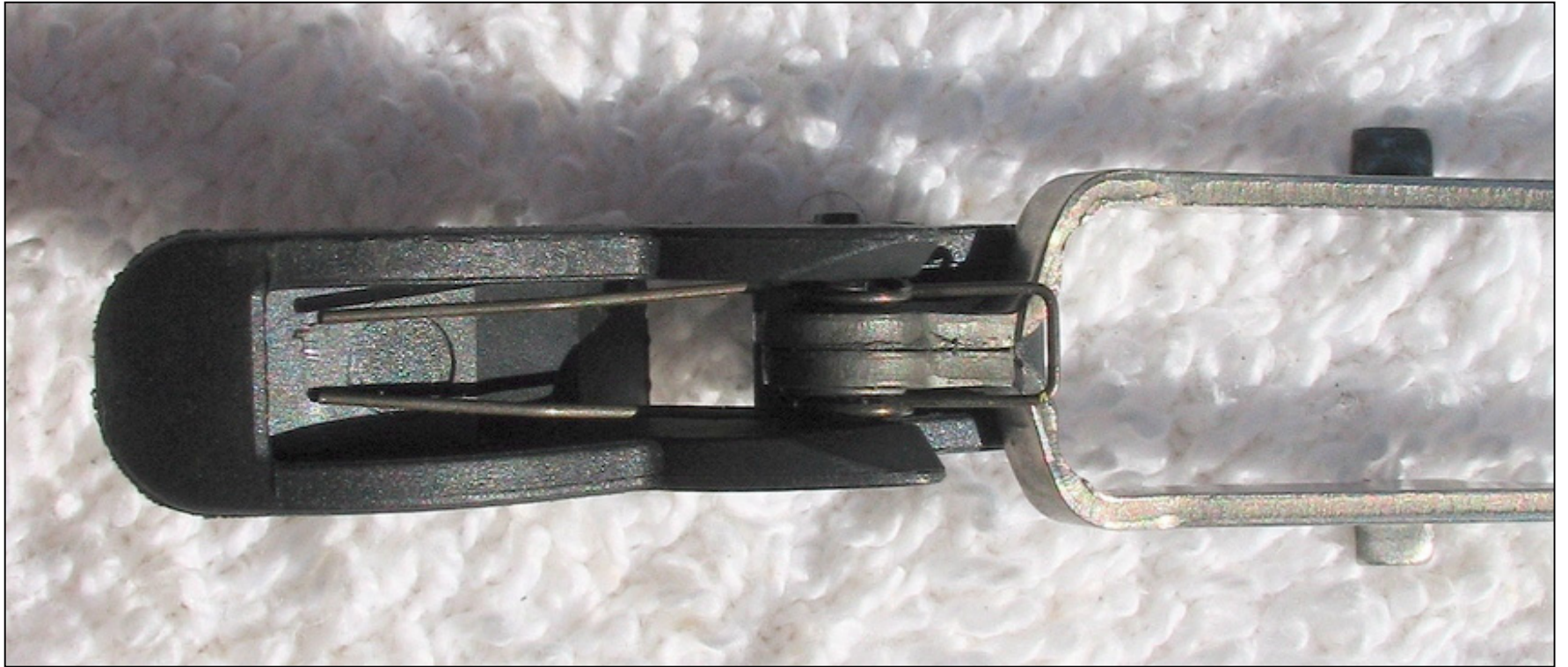

close-up, underside of trigger

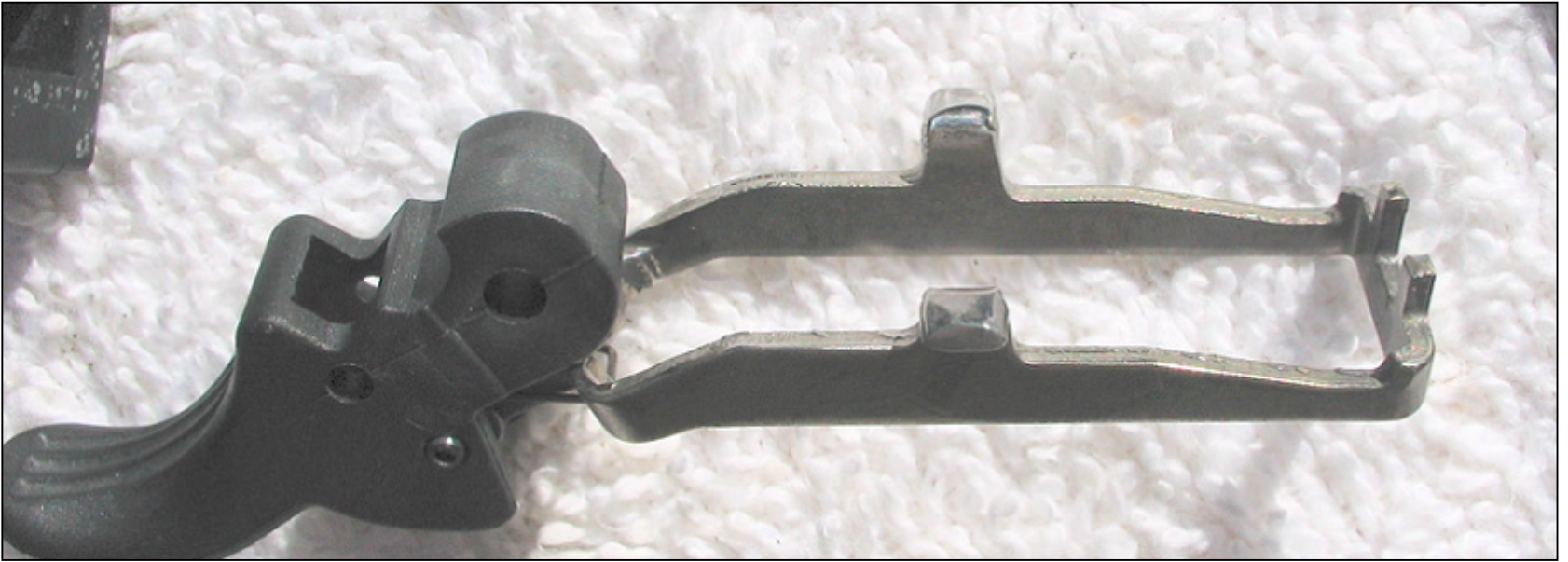

Another close-up of trigger assembly

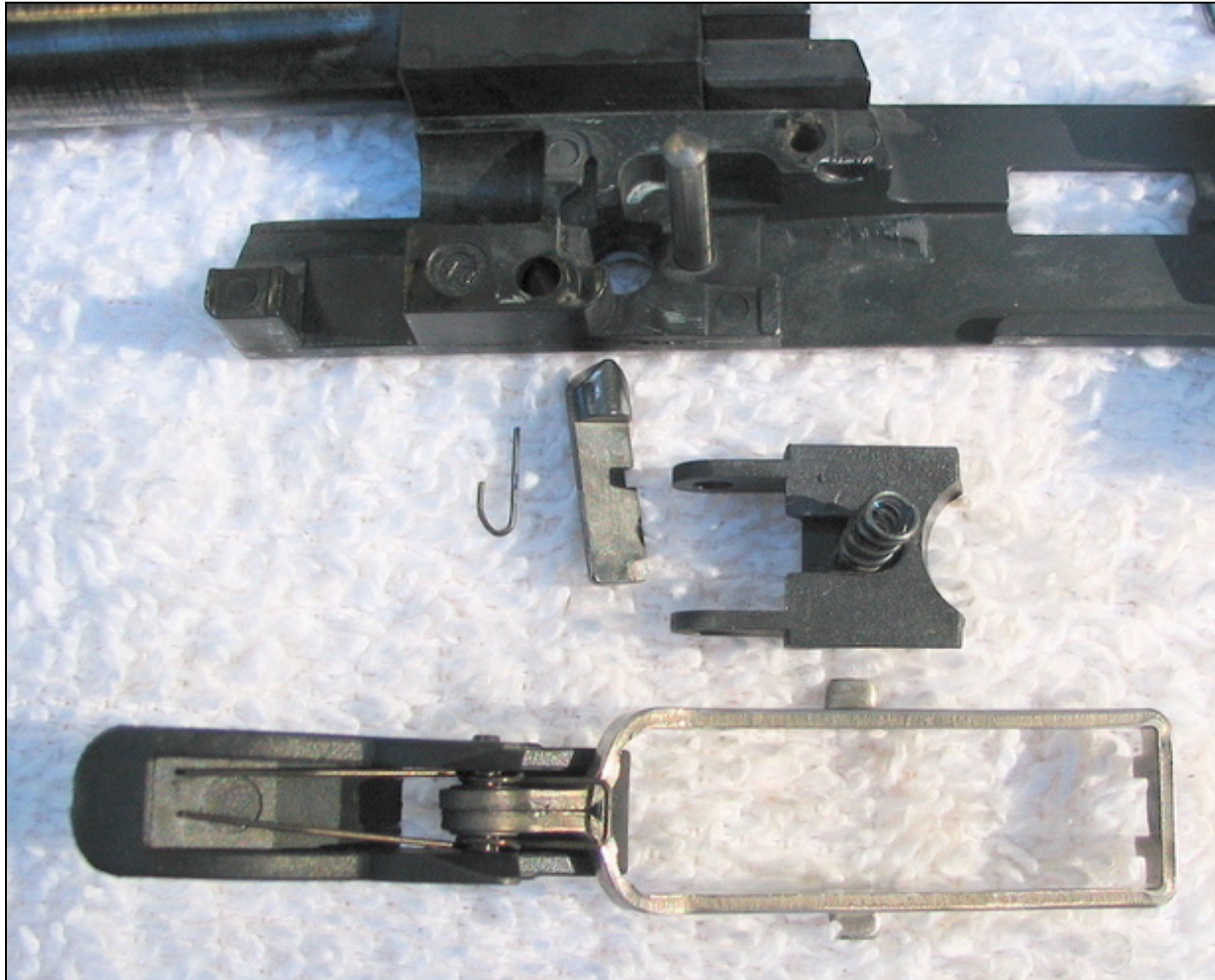

Trigger components, magazine safety disconnect, etc. To reassemble this first I install the hammer/sear. I then half cock the hammer to allow room for the rear of the trigger bar to fit into the hammer components properly. I then install the internal safety, set to fire position, followed by the little spring that accompanies it. I then remove the double spring and install the magazine disconnect safety and trigger components over the trigger pin, wiggling the rear of the trigger connector under the hammer components as I do.

I then make sure the trigger pin is sticking through enough to hold everything in place while I carefully compress the double spring, sliding 1/2 of it under the right side frame where hopefully it will stay while I press on the left side of the frame. Some people do this in a baggy so if it slips off and flies away it can't go far. I then make sure the trigger pin is positioned far enough to the left to properly hold the slide catch mechanism.



Hammer/sear components



Sear, notice spring position. The ear sticking up will rotate forward to a horizontal position upon reassembly and will have to be pressed down for reassembly of the hammer assy.

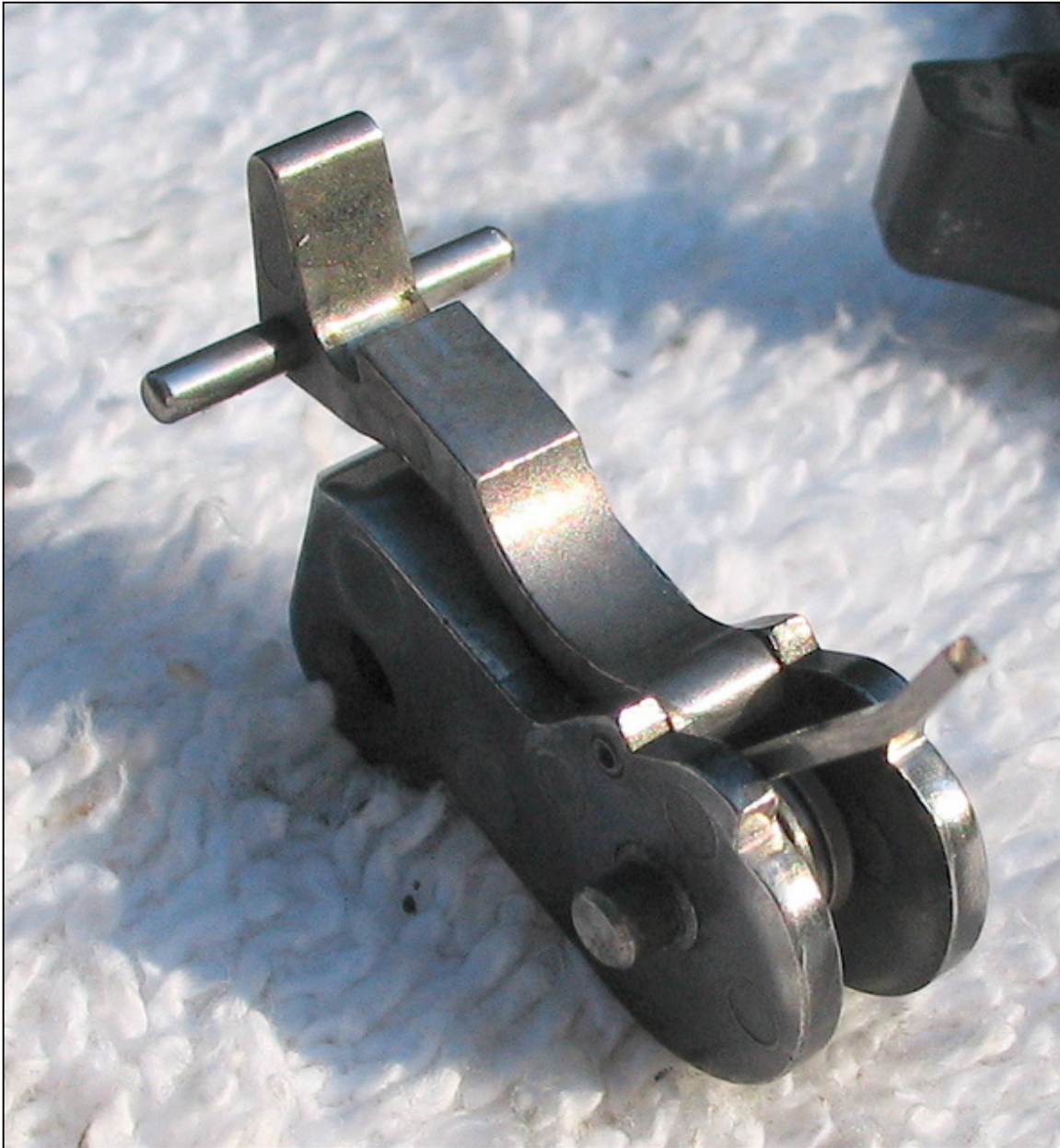

Hammer components, center pin must be set with shoulders flush on each side upon reassembly.

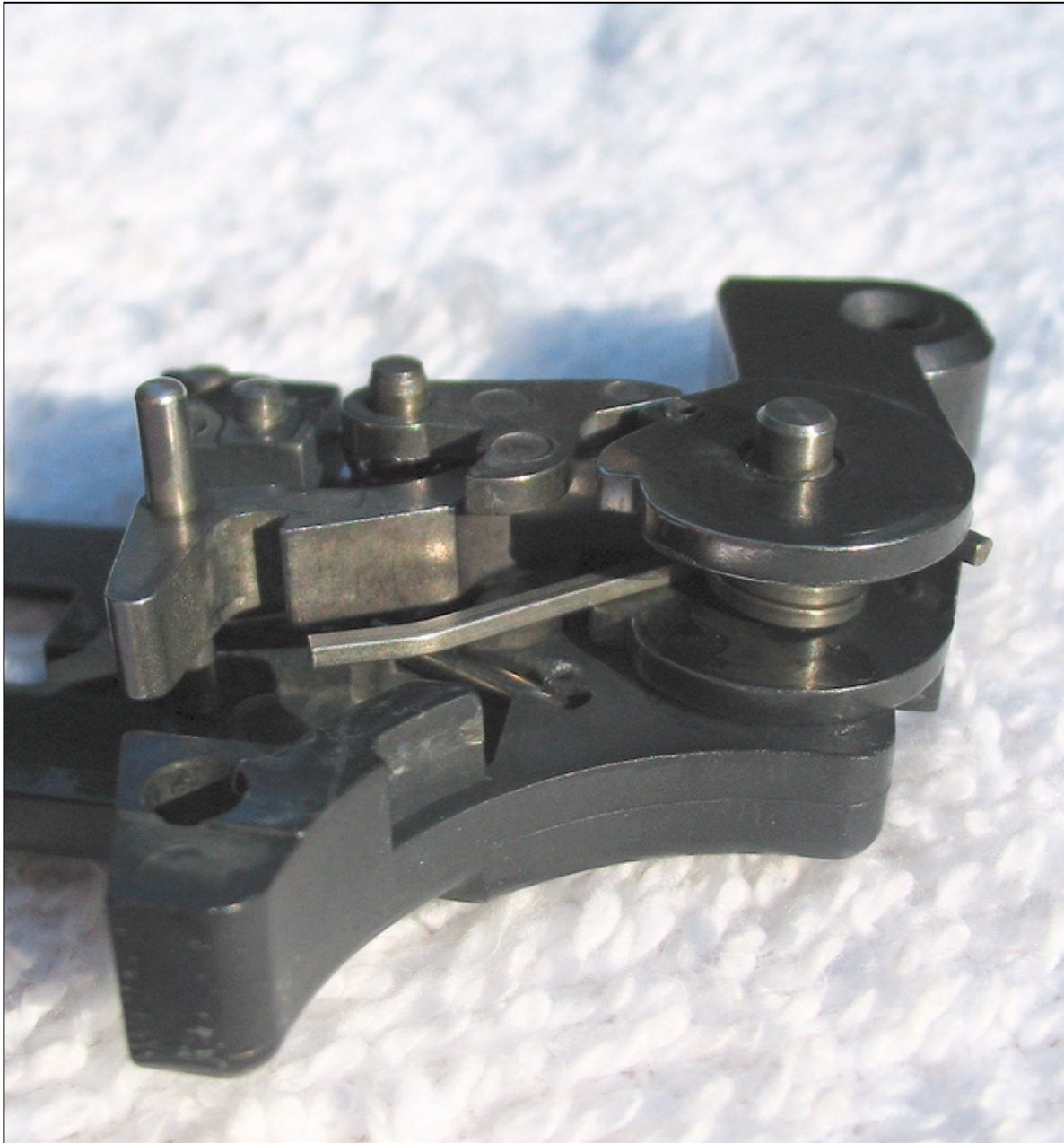

Hammer assy. reassembled onto pistol frame. Notice how the connector fits between the legs of the sear, how the hammer and pivot pin are seated and how the hammer spring is in a relaxed position for reassembly. The hammer spring leg will now be lifted slightly and placed behind the frame for proper tension. In this photo the hammer is still in a relaxed position with the sear exerting no influence.

In order to fit the trigger bar into the trigger assembly it will be necessary to place the trigger in the half cock position, carefully, so as to not dislodge it from the right side frame where it is now held by the pivot pin. Upon reassembly of the frame halves it takes a little wiggling to align the hammer pin on the left side into the hole it fits in. Not hard to do just a little wiggling.



Hammer spring now placed in the proper position for reassembly. Note no lubricant is shown as I now lubricate with a spray of Rem Oil with teflon, blown off with compressed air followed by an application of dry moly/teflon powder applied with a q-tip.

The components you are looking at in this thread have over 16,000 rounds of wear or lack thereof. The photos have also been photo-shopped slightly to bring out details so some may appear slightly weird in color and texture.



The roll pin must be pressed out in order for the breech block to be removed. Believe the safety must be rotated to fire position also. The breech block then slides out forward along the inside top of the slide.

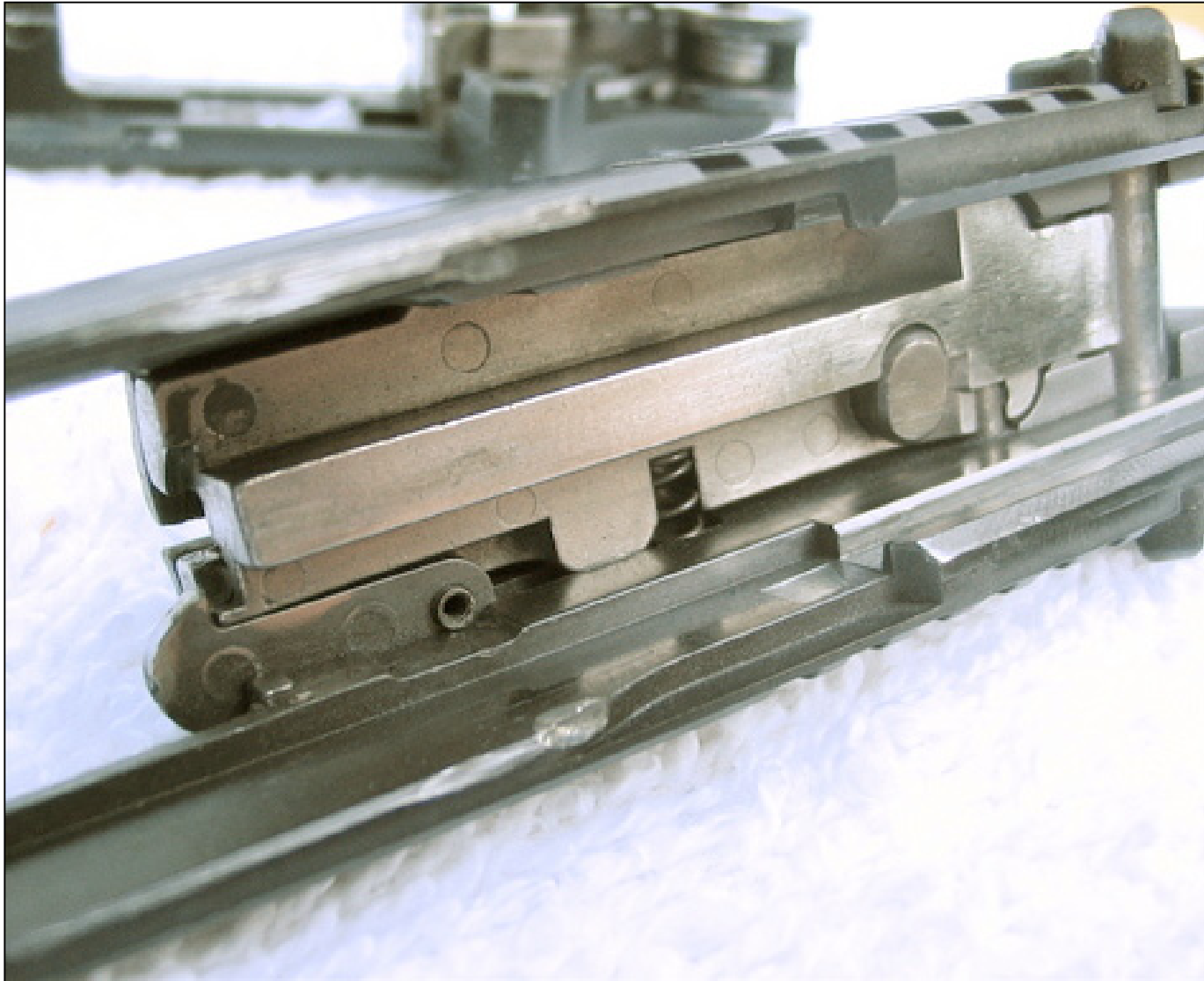

The breech block properly installed. You may be able to see where I removed 0.020" from the rear of the underside of the breech in order to give greater relief of hammer drag. Works fine too. Leave the rear portion ramped up to the safety roll bar to keep things smooth. Note the oval firing pin disconnect button, the thing that dents the little hump. With the small spring correctly installed on top of this piece it can be pressed up and down and should work smoothly. Also notice the extractor and pivot pin that holds it in place.



To remove the extractor and spring, take a drift pin and press this small roll pin out the bottom of the breech block.



The extractor and spring will then fall out. reverse for reassembly. Note that this spring has been stretched. The extractor has had the tip peened and the nose carefully polished where it rubs against the chamber groove. All of this to correct ejection direction. Works too.



Extractor pin reinstalled and seated flush.



Plastic guide bar installed through the slide and spring. Notice it is pressed against the guide bar. Simply pull the slide rearward with the hammer cocked and the spring/guide bar will allow the slide to easily be reassembled. The slide is pulled rearward just enough to reengage the slide grooves on the frame rails. With the slide in the fully rearward position you will have to press down slightly against the hammer tension to properly align the grooves/rails before you are able to slide the slide forward. Then simply push the polymer slide release mechanism back up and it is back together.



Put it back together right and it will still look like a P-22.
 Then you can do some shooting. Hope this helps, 1911M

A few more pictures of details I left out.

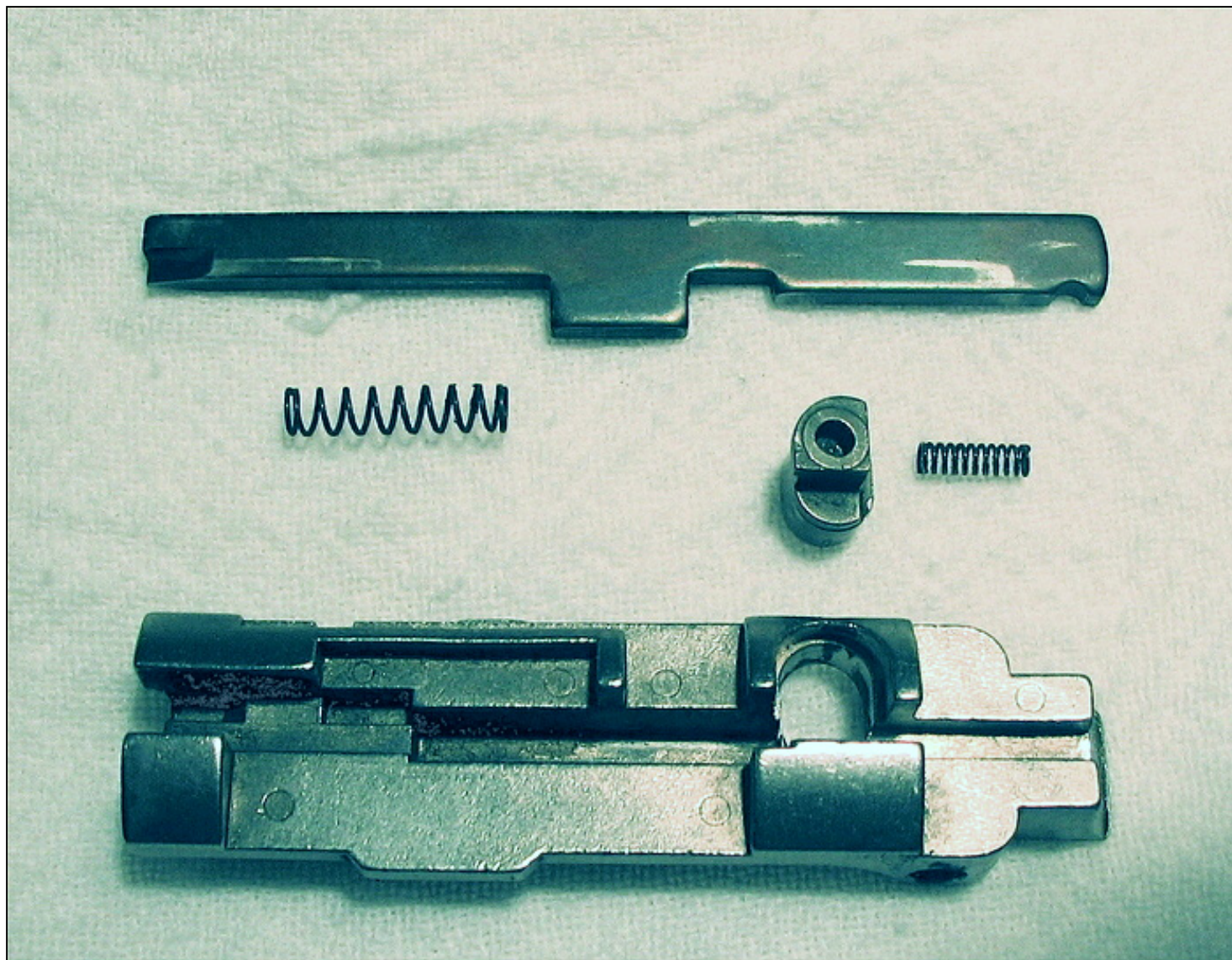

This photo show the components of the breech block in their proper relationship.



This photo shows the properly reassembled breech block.



Photo of the proper position of components upon reassembly of the slide stop mechanism.



Slide stop properly assembled. This component must be held in place while the frame is inserted into the polymer housing which will then hold it in place. It should move up and down freely once installed in the frame.

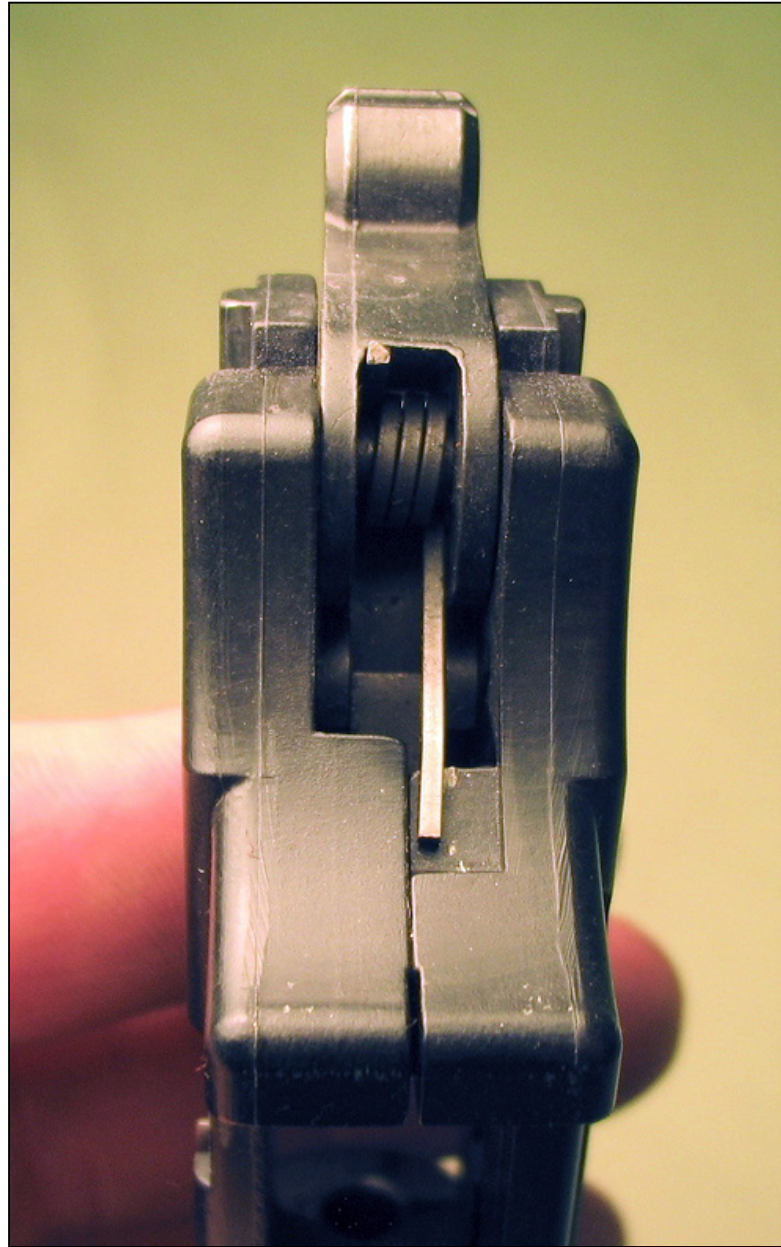

Picture of the rear of the hammer and correct hammer spring placement.

Part 2

Functional Improvements (MODIFICATIONS)



WALTHER P22 BIBLE

1917-1911M

As you have probably read the "test gun" frame developed a hairline crack at approximately 27,500 rounds. There was absolutely no wear to the frame rails or slide grooves, only cosmetic wear to the finish. The pistol still fired very reliably with the cracked frame but I doubted the safety of continued use. S&W offered to repair the pistol or send me a new one - free. I chose the new pistol. I haven't fired it.

I removed the new slide, found damage from sharp trigger bar ears and haven't put it back together. So why am I modifying a new P-22? There are several inherent problems I've seen with all P-22s regardless of whether they fire reliably or not. These are problems that sooner or later, in my opinion, need addressing. I intend to address them up-front and then enjoy plenty of trouble free shooting. Three items can't be modified to prevent problems; a slide or frame that fractures and hammer spring breakage. Any of these S&W must either repair or send new parts.

I am not a gunsmith with formal training so take anything I post with a grain of salt. Anything in this thread you don't understand will be clear to a gunsmith. Get expert help if you need it. With a little practice and patience you won't need it.

Routine, recurring, solvable problems are:

1. Sharp trigger bar ears that damage the slide and ears that don't fully engage the slide ramp which can cause accelerated wear even with polished ears.
2. A hammer tip that catches on the safety bar causing the slide to fail to complete its cycle and in the process fail to chamber a round. The stock hammer tip will alsopeen the metal on the bottom of the breech block and is usually not square but rather drags on one side or the other.
3. Poor spent casing ejection direction resulting in hot brass flying everywhere including between the eyes. One member recently reported his wife actually hitting a spent case that was ejected forward with the next round. This is not only aggravating but is not safe.
4. A safety that can rotate from safe to fire or just the opposite on its own from the hammer tip dragging on/across the safety bar or from vibration caused by a hammer strike or firing.
5. A barrel nut and two frame screws that will not stay tight without blue threadlocker or similar.
6. Check the magazines received with the pistol to see that they freely hold 10 rounds of ammo. If that 10th one has to be shoved in really hard don't expect the slide to operate correctly.

7. Grease and oil packed in interior spaces of the pistol. We have determined that these two products collect spent powder and other debris resulting in an abrasive mixture that is damaging to the zinc pistol. All traces of oil and grease should be removed and replaced with dry lubricants and/or powdered lubricants of teflon or molybdenum.

Before disassembling the pistol insert and eject a fully loaded magazines several times. It should smoothly lock and unlock from the pistol without undue effort. I recently inspected a pistol that was extremely hard to lock or unlock a magazine in. I removed the inner spring from the double set that control this feature. This made magazine insertion/ejection much easier. Regardless of how I held the pistol or shook it while operating the trigger without a magazine, I could not engage the hammer. Therefore, removing the extra spring did not immobilize the magazine safety. Other pistols work fine with both springs.

One other test I do with the slide off is to depress the sear arm so I can manually thumb the hammer back and forth 100 times or so. If the hammer spring is going to break, I want it to break now so that I can replace it while the pistol is apart.

The above problems can all be solved with simple modifications where required. Following are the details on what I do. When I'm through I will be able to let the slide forward slowly even with 10 rounds in a magazine, even trying to make it hang up yet it will complete its cycle each time I release my grip. Follow along if you wish.



After testing how the magazines lock and unlock, remove all ammo from the pistol, make sure any magazines you might use for additional tests are empty and relocate all ammo to a drawer or some place separate from where you are working on the pistol. Gather your tools and find a comfortable work space, desk top or bench.

Tools; small hammer, two drifts, a flat or Phillips screwdriver for removing the frame screws, the barrel nut wrench, an assortment of emery paper, 220 grit, 320, 400, and 600 That will be enough, some clean rags, Remington Remoil and Gunscrubber or other similar products, some emery fingernail files, a Dremel with attachments and some Permatex "blue" threadlocker or similar. Not red. Camera if you're keeping track of all your work for the fine folks at the Walther section of RFC.



I completely disassemble the pistol as shown above. This gives me a chance to inspect the parts and perform any needed modifications and clean them. Refer to the disassembly/reassembly thread if necessary.

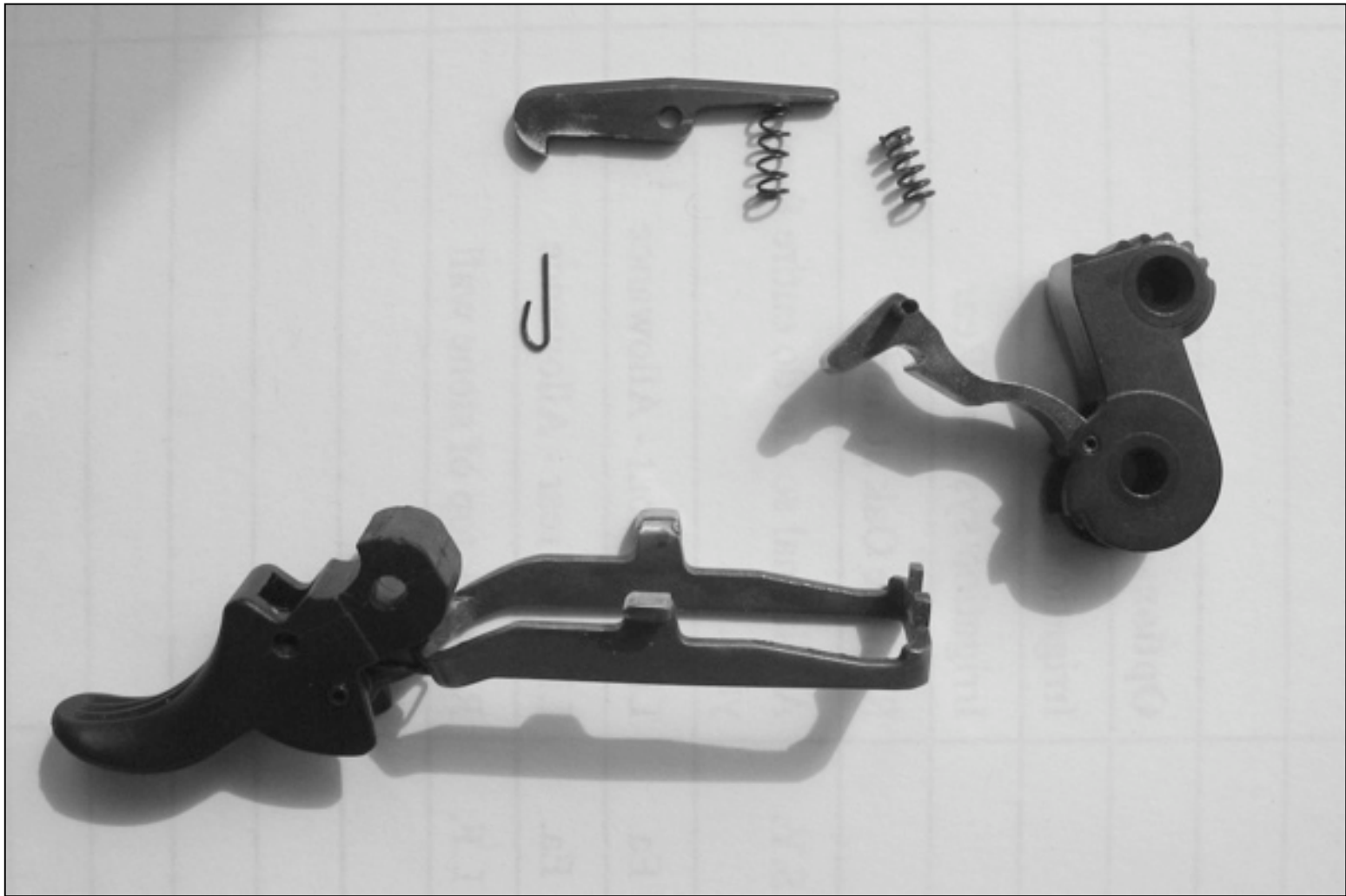

These are the parts that I found needing modifications in my new '06 P-22. The J spring holds the internal safety in whatever position you place it. My spring wasn't expanded enough at the bottom of the J and didn't fit tight against the safety bar. It could fall out. If you find this situation, simply expand it so that when you install it tension keeps it locked in it's place in the frame.

Also show is the extractor which will be peened to correct ejection direction, a modified (stretched) extractor spring as compared to a stock one, the trigger bar and hammer with it's troublesome "tip". Notice that in this picture some of the parts are already modified. Ignore that for the present.

**Functional Improvements
(MODIFICATIONS)**

Trigger Bar Ear Fix



In the above picture you will see some sizable chunks of zinc that have been taken out of the slide by the sharp trigger bar ear. I say ear because only one ear is hitting the slide. This pistol has only been fired once by Walther and the slide then removed by me. The trigger bar ears causing this amount of damage won't do. Imagine the damage from 1,000 rounds. Also notice for later modification discussion that the ear is only engaging about 1/2 of the ramp. Wear here will be less with more surface contact.



The top front edge of the trigger bar is usually the only portion requiring radiusing and polishing. On this pistol, not only was the front edge sharp but the sides and the top. All of these edges will now require smoothing and polishing. You only want to remove enough material to get the job done, not grind the ears away.

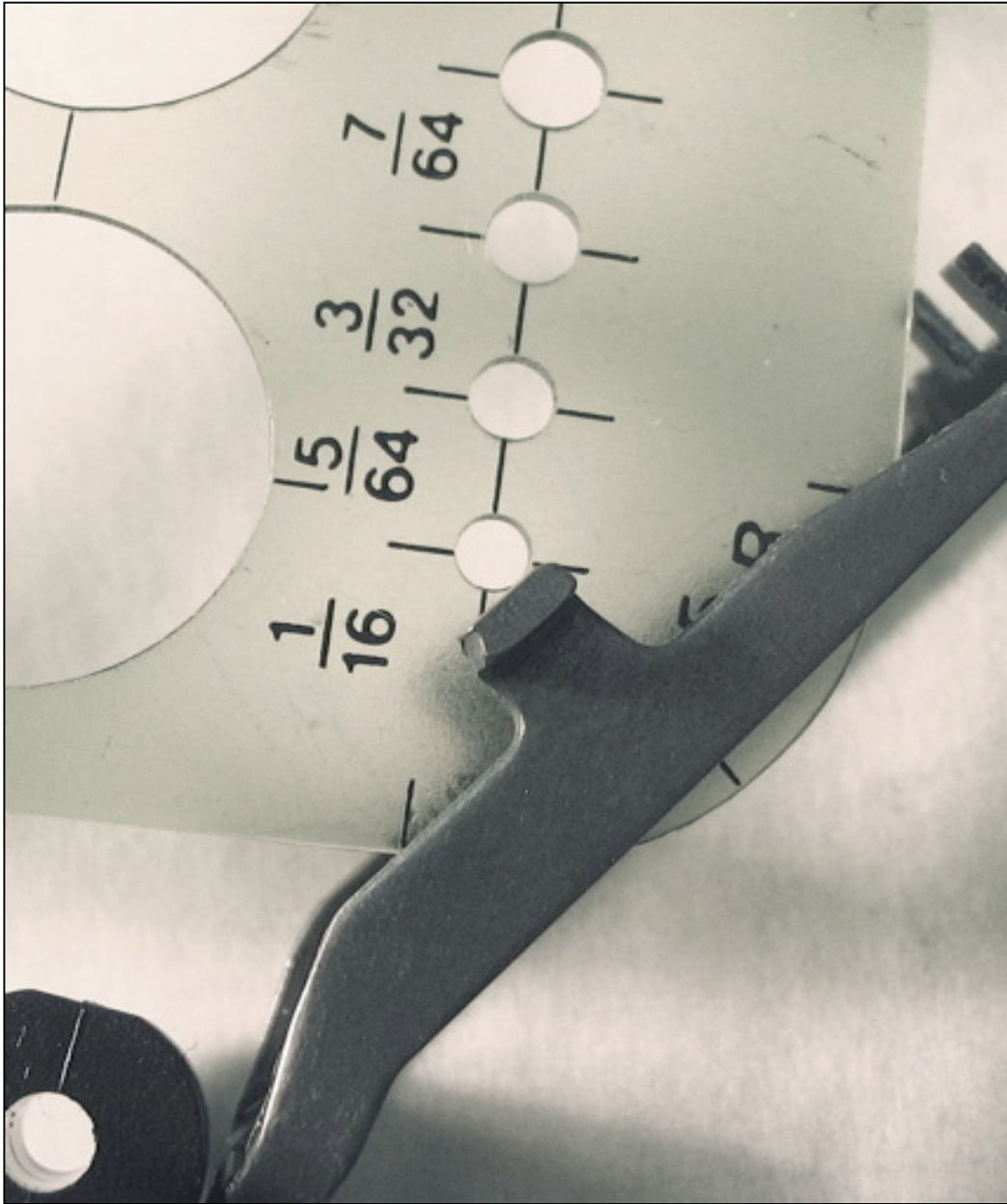

This is a photo of the other ear. Notice how sharp the top front edge of this ear is. When the slide moves rearward the ear slides down a "ramp" located on the underside of the slide. This ramp presses the ear/trigger bar down disengaging it from the hammer assembly. This interaction occurs each time you fire a shot and it occurs very rapidly.



This photo show just how rough these ears are from the front, not only the front edge but the sides and the top.



I placed a small piece of 220 grit emery paper flat on a hard surface of my work bench. I then turned the trigger bar upside down and with the top of the ears placed flat on the emery paper, I gently rubbed them back and forth just enough to remove the raised protrusions. I then used the Dremel to remove just enough of the material from the front edge to begin the radiusing process. Careful now, don't get carried away with that Dremel. Just barely round the top of that front edge. Remember, power tools can cut very quickly and jump around on you. You could do all this by hand but tools sometimes speed you up a bit. The Dremel will really come in handy when polishing.



I then use fingernail files, not the sandpaper kind but the better ones you can find in the grocery or drugstore. They have emery grit on them, are durable, come in grades from coarse to very, very fine, 1500 grit or finer. An added benefit for most applications is that they "give" if you press your work piece into them which rounds the edges of whatever you are polishing without any extra effort. If you don't want any rounding, lay a piece of emery paper on a hard surface like your desk top or glue a piece to a popsicle stick.



Take your Dremel, put on the polishing attachment and polish those ears . Don't forget to polish the top, front and ends. You might also touch up the rear legs just "because" you can.

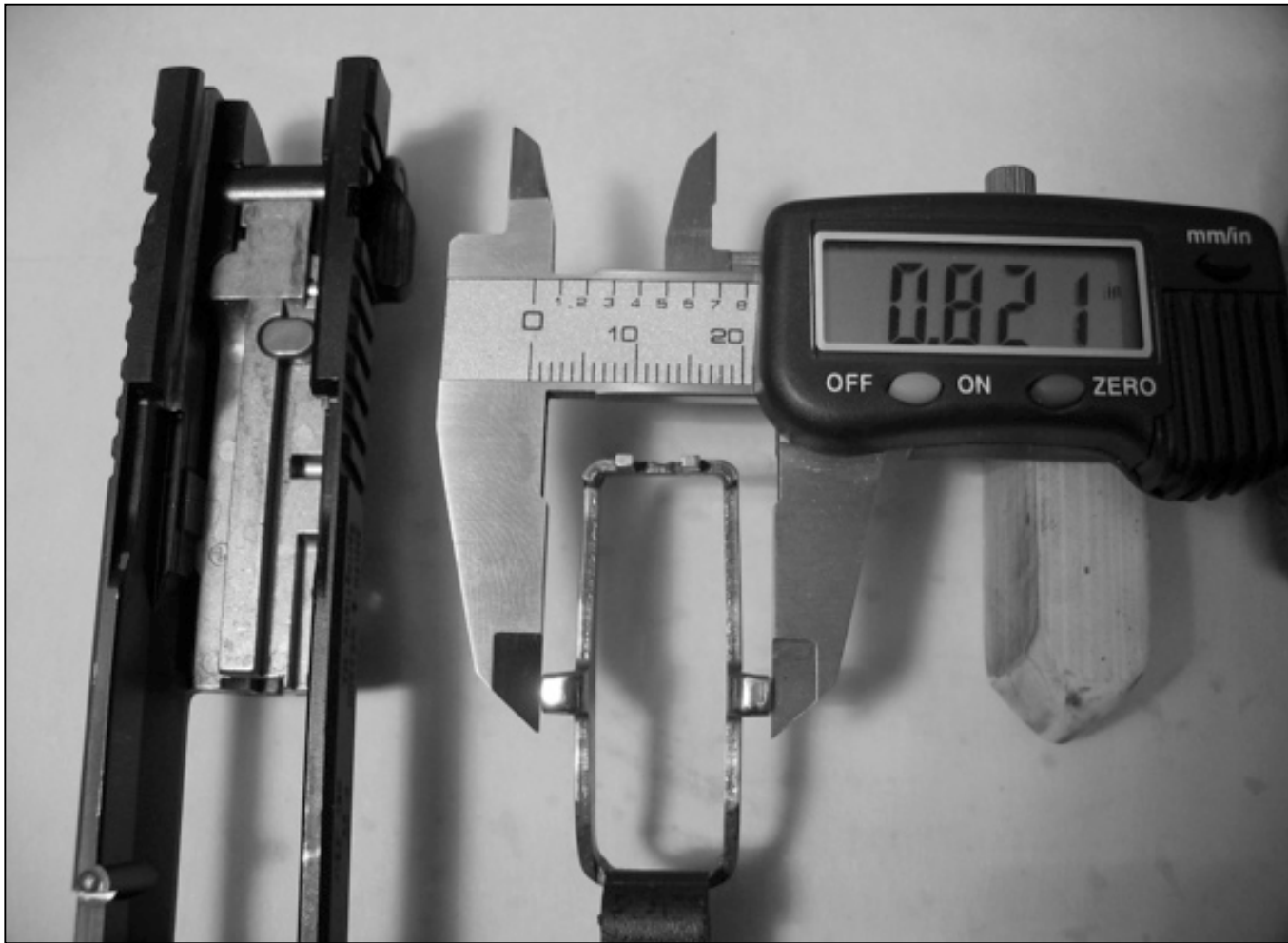

I want those smooth trigger bar ears to spread the impact over most of the ramp width under the slide. The inside dimensions of the slide measures 0.830" here and the stock ears measure 0.785". This leaves quite a gap and the ears are only rubbing on about 1/2 of the slide ramp. I want to spread them to the point where they are just slightly narrower than the slide width here yet don't bind in any way. The above trigger bar has been spread so that the ears are within 0.009" of the two ramps overall width.

Warning: Some of the mods I'm showing here are really kind of touchy to do. Rounding the ears and polishing them is easy and will provide 10's of thousands of rounds fired through the pistol with denting of the underside of the slide but the pistol will still function properly. Don't go overboard just because I did. I'm really familiar with the P-22 and enjoy fooling with it. You may not want to go to some of the detailing I do.



In order to make the ears spread I placed the trigger bar on top of a large socket and then took a smoothly tapered socket and lightly hammered it. This process spreads the trigger bar ears just right. What you want is to spread the ears without spreading the bottom rails of the trigger bar too much or they will drag on the frame. Like a lot of other things on this pistol, just the right touch is required or several attempts to get it just right. I'll get a measurement for the rail spread and add it here shortly. If the rails spread too much, simply press them back together with your fingers or tap very lightly with a hammer. One way to keep them from spreading too much is to place them in a vise or in the jaws of a crescent wrench to hold them steady while you spread the ears. This is all very easy to do.

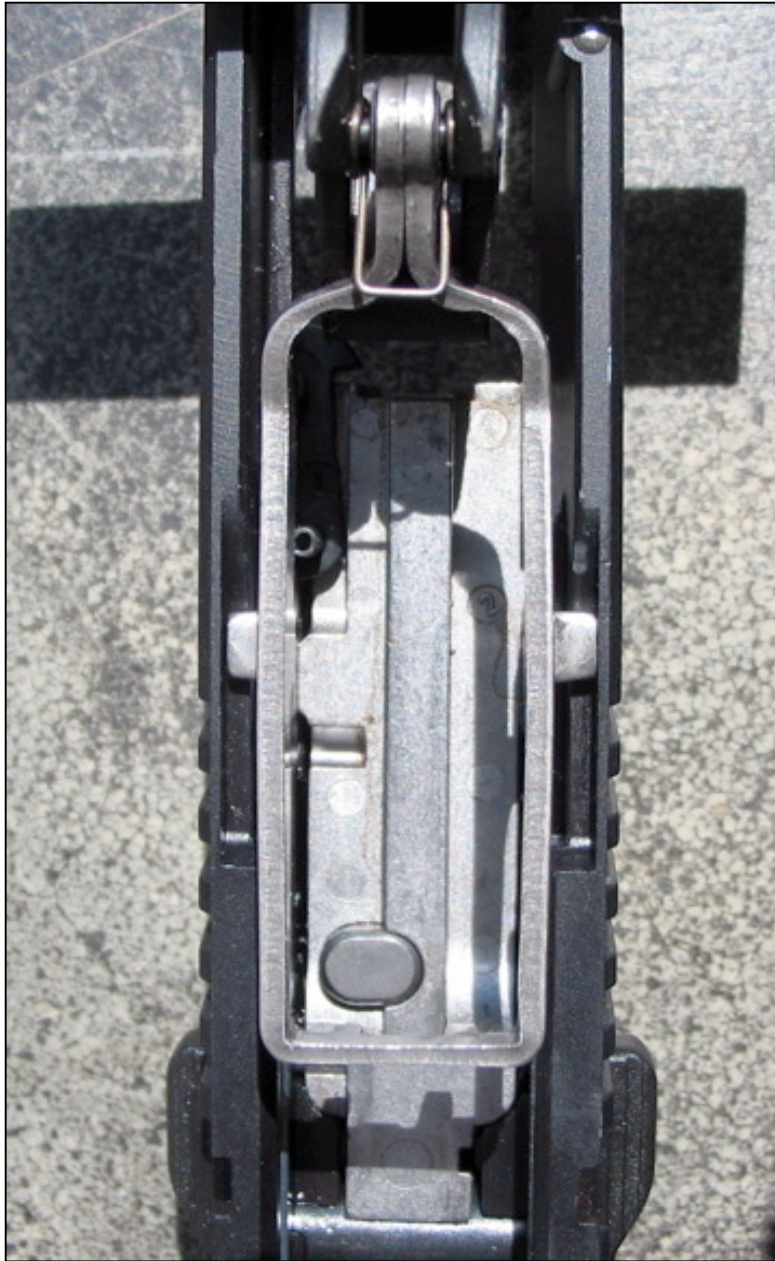

Nine thousandths of an inch looks just right and a test run of sliding the trigger bar up and down the slide ramps, even with it slightly cocked to one side or the other indicates smooth running here. Notice how much more of the ramp is engaged as compared to where the sharp ear took a bite out of the ramp. One important note here is that the width of the frame where the trigger bar moves is 0.610" wide so the trigger bars (not the ears) can't be spread quite this far.

If you choose to spread the trigger bar ears reassemble the frame halves without all the other components just the trigger and trigger bar to make sure you still have clearance and a smoothly operating trigger. Insert the ears in the slide and move them up and down the ramps. Make sure you have a little clearance. The trigger bar ears can't drag on the slide from being too wide, neither can the trigger bar rails inside the frame. My measurements are at the max.

**Functional Improvements
(MODIFICATIONS)**

**Hammer and Breech
Block/Safety Bar Fixes**



The next area to check is the safety bar. The hammer tip on many P-22s catches in the small valley that is between the round safety bar and the rear of the breech block. On some P-22s the safety bar actually hangs down below the breech block and makes this situation worse. This is one way to determine if yours does. As this piece of straight bar is lying flush across the bottom of the breech block and the safety bar, this safety bar is not hanging down and requires no further treatment.



The old "test gun's" safety bar hung down below the breech block. Since the only time I would really be concerned about increased drag here is when I am "firing" the pistol, I place the safety lever in the "fire" position and grind off just enough material to make the bottom of the bar flush with the breech block. This needs to be done for the entire width of the hammer. This is not the area that blocks the hammer when in the safe position but is close to it so don't get carried away here. Remember, safety in the "fire" position for doing this.

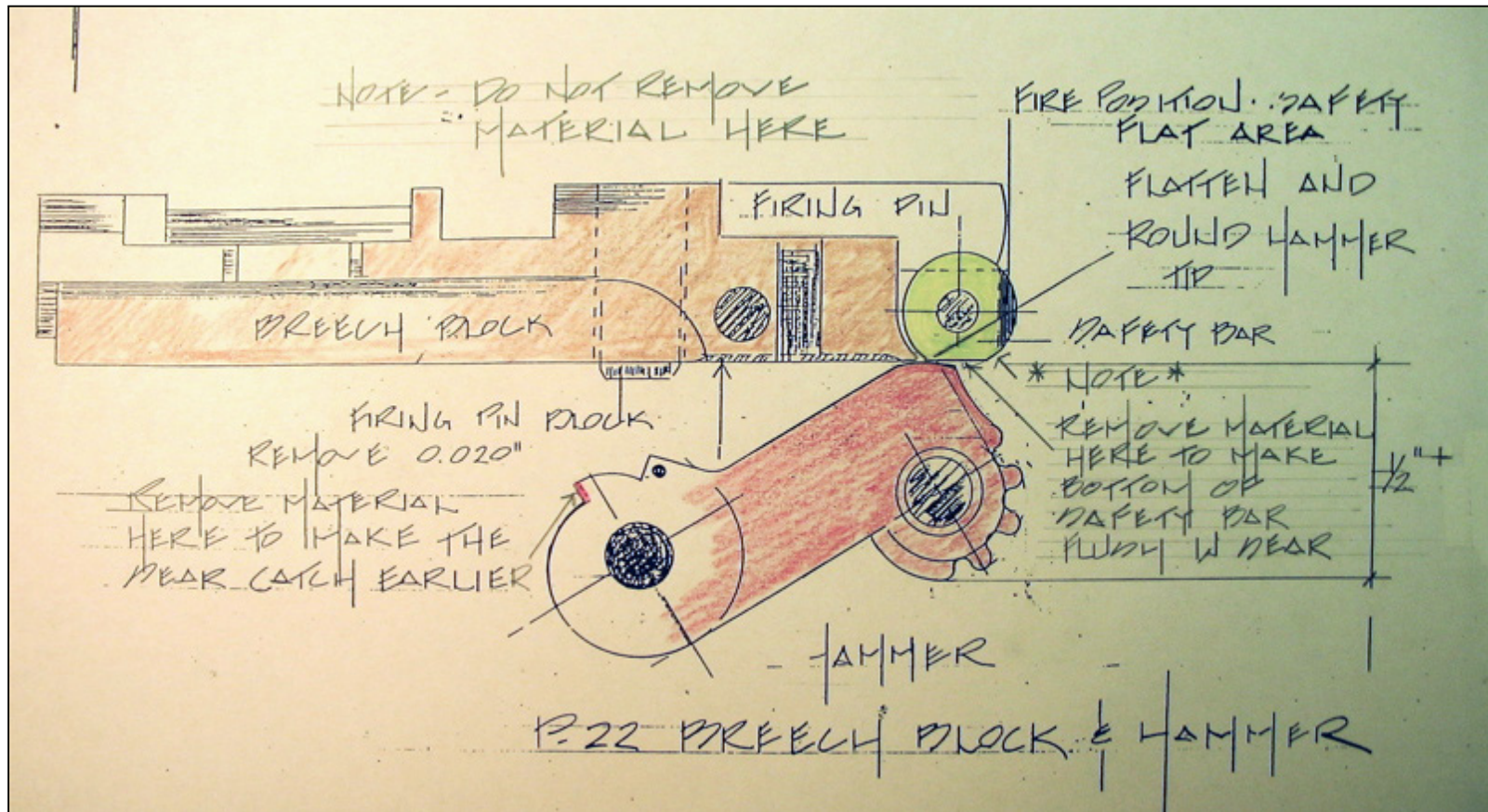

This is a drawing of the processes we are doing and will be discussing regarding re-profiling the hammer's tip, removing material from a safety bar that hangs below the breech block, if your gun has that situation Also shown is where to remove material from the hammer's cock notch should you remove too much material from the hammer tip in the process of reprofiling it causing the slide to no longer be able to cock the hammer. You may also have to modify this notch if you have slide wear in the grooves and the slide is lifting and no longer cocking the hammer.

WARNING. This is the area where the sear engages the cocked hammer. Work in this area is serious business. Done improperly and the cocked hammer could slip off the sear causing the pistol to discharge. Work here is not difficult but you "must" know what you are doing. If you don't understand it, see a gunsmith. It's that important.

NOTE: Removal of the 0.020" refers to removing material from the bottom of the breech block so that once a cocked hammer clears the safety bar it no longer drags on the breech. Advanced work for the expert. Please disregard. Also the statement "flush with the sear" should say ""flush with the bottom of the breech block". Carry on.



I lifted this picture of an original style, unmodified hammer from a recent tread without permission. Don't say anything. This "tip" was especially prone to catching in the roll bar/breech valley.

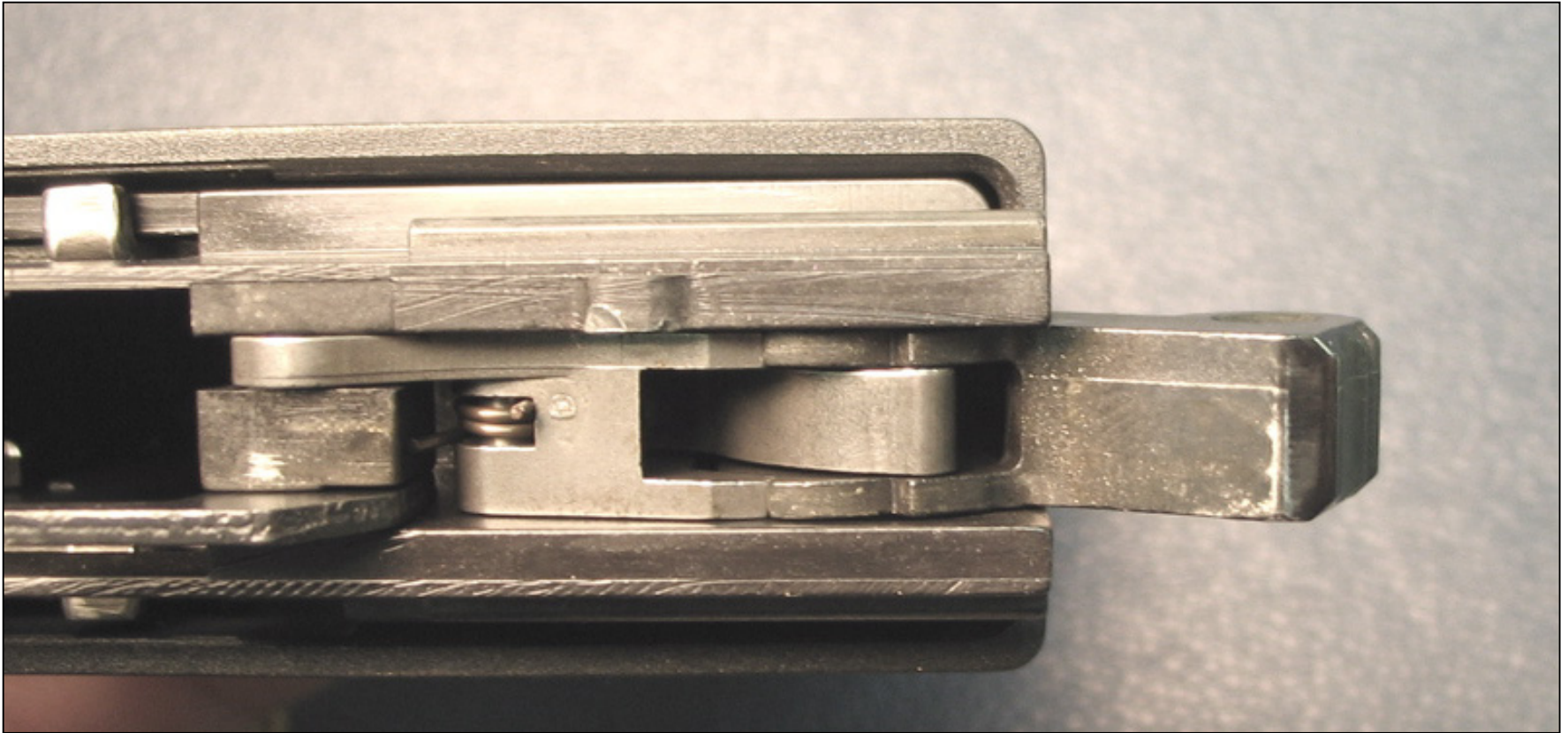

But, the new style hammer still has a "tip" as Walther didn't get it quite right. See the shiny area at the new tip where it rubs on the safety bar/breech bottom. It will still catch in the valley. Next we will discuss re-profiling the hammer tip to eliminate this.

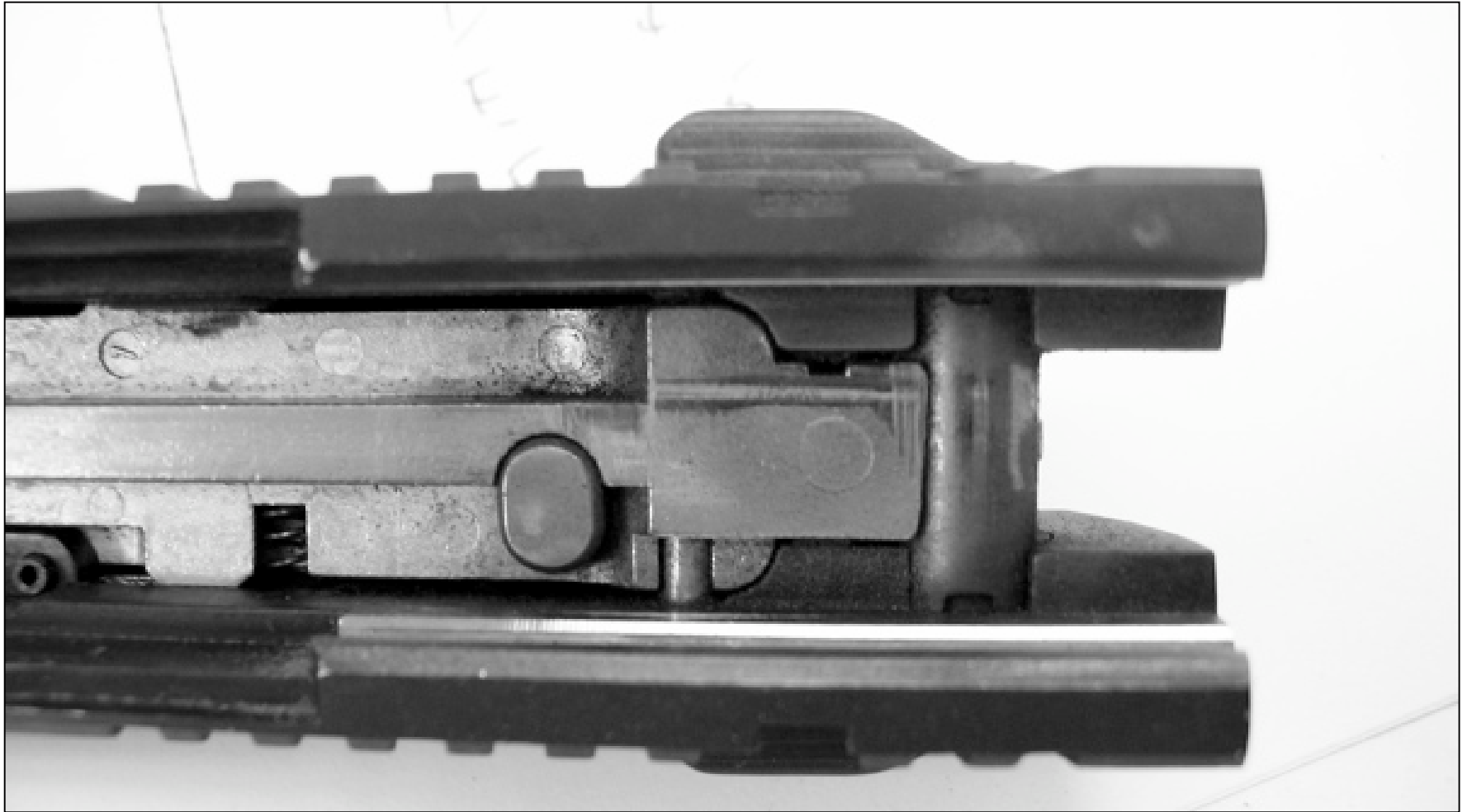

While we are re-profiling the hammer's tip, we might as well square it up. Nearly all I've seen drag down one side or the other and if you look close you will see where the hammer tip, even the new one, is actually peening the bottom of the breech block. See the three lines just in front of the safety bar. A "re-profiled" tip cures all here. We are now spanning the valley and squarely.



You begin by rubbing the hammer tip on a piece of 220/320 grit emery paper to eliminate any "point". Frequently check your work and make sure you are removing material from the right area and doing so squarely. Remember we are looking for a profile similar to the one in the drawing, flattened the top of the hammer parallel with the bottom of the breech block and then slightly round it.

Yes you can do this with the hammer in the pistol and an emery stick but you must be the kind of person that is very patient and you must thoroughly flush the pistol and lube when finished. Gotta take it apart anyway some time or the other to replace that broken hammer spring.



New style hammer ready for re-profiling.



This is what an unmodified new style hammer measures face to rear of thumb grip.



After about 1 min of sanding on the emery paper the hammer will look like this.



When you have finished the new hammer profile will look like this and be about as thick as the caliper measurement shows for this modified one. BTW, when I reassembled the pistol, the slide still cocked this hammer so if you have access to a dial or digital caliper stop right around this thickness and you should be good to go. All that remains now is some buffing with 400 grit emery paper, then 600 grit, then the Dremel. Then you can see your smile in the reflection given off by the hammer's new face.

**Functional Improvements
(MODIFICATIONS)**

**Chamber Lip Enhancement
for Improved Hollow
Point Feeding**

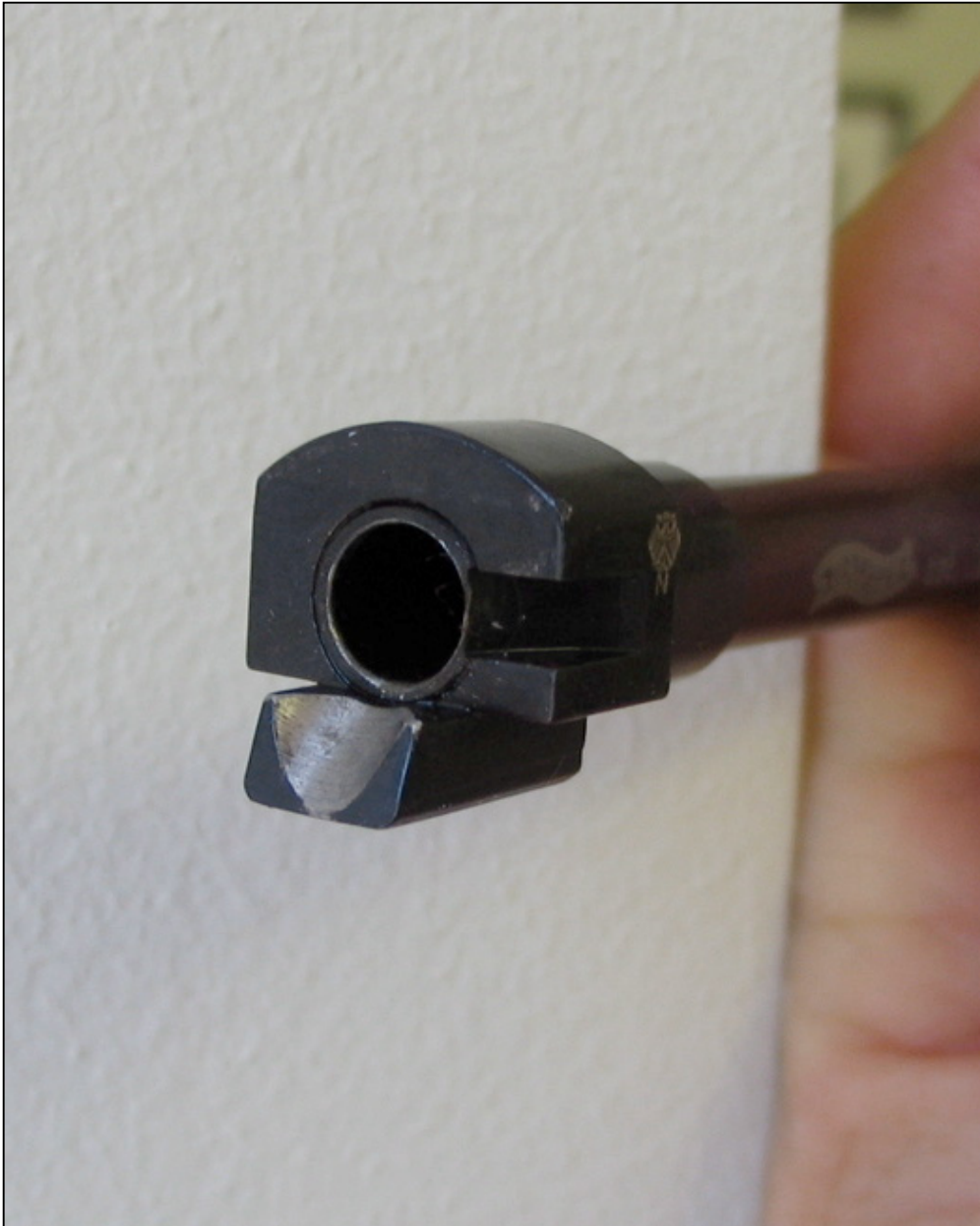

One area I do a little modification on "just in case" is to lower the bottom lip of the chamber so hollow points won't catch here. Pictured here is a stock chamber rim. I do this with a carbide tapered Dremel cutter, #9910.

Very lightly now, then polish. You can feel the improvement just by slipping the nose of a hollow-point over the feed ramp and into the chamber by hand.



This is what the final product looks like all polished up. Be sure you clean the barrel really well after this procedure.

**Functional Improvements
(MODIFICATIONS)**

Extractor Enhancement

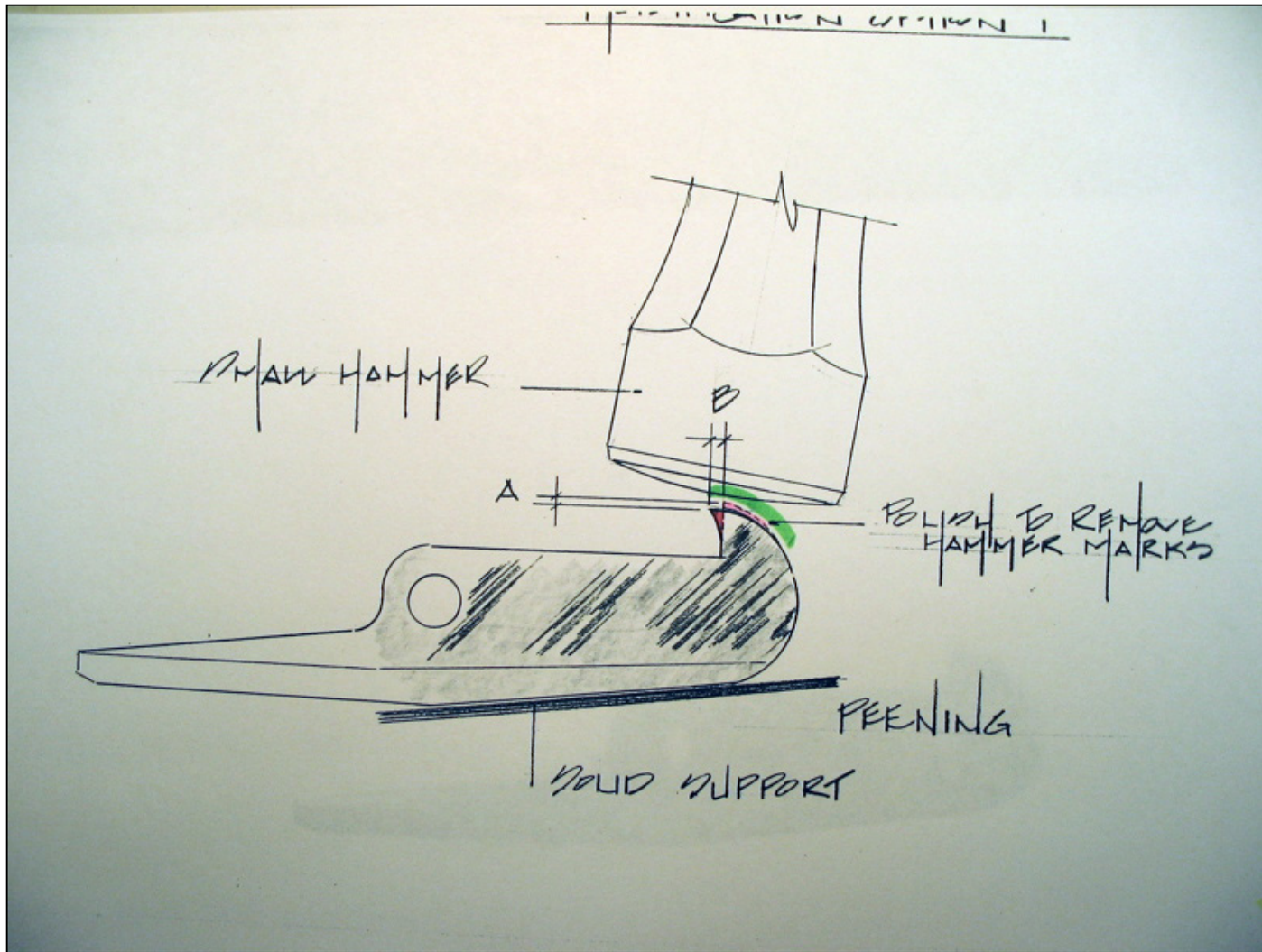

P-22s typically eject spent cases in all directions including forward, against the bottom of the red dot or scope mount causing jams and right between your eyes. This is annoying. Until I figure out how to improve this situation with a new hand-made extractor this is the best I've come up with and it works. Not like a Ruger MK or 10-22 but much better. First stretch your extractor spring.

That will help but if you aren't satisfied you've got to peen. What we are trying to achieve is pictured here. The gap from the face of the extractor to a chambered rounds base is reduced and the sharp edge extracts/ejects the round better. I've never been able to affect any improvement with work to the ejector. I leave it alone.



My anvil, a 2 lb hammer head and a small hammer. Many light taps required. I beat the heck out of the sides of one today and nothing gave. Whatever this material is, it is hard to change it's shape. It is brittle also. Don't hit it hard.



Picture of the new extractor modified in such a manner and installed in the pistol. This peened one will work much better than the stock one. Be sure to polish the backside of the head where you were hammering so it will ride smoothly against the slot in the barrel chamber.

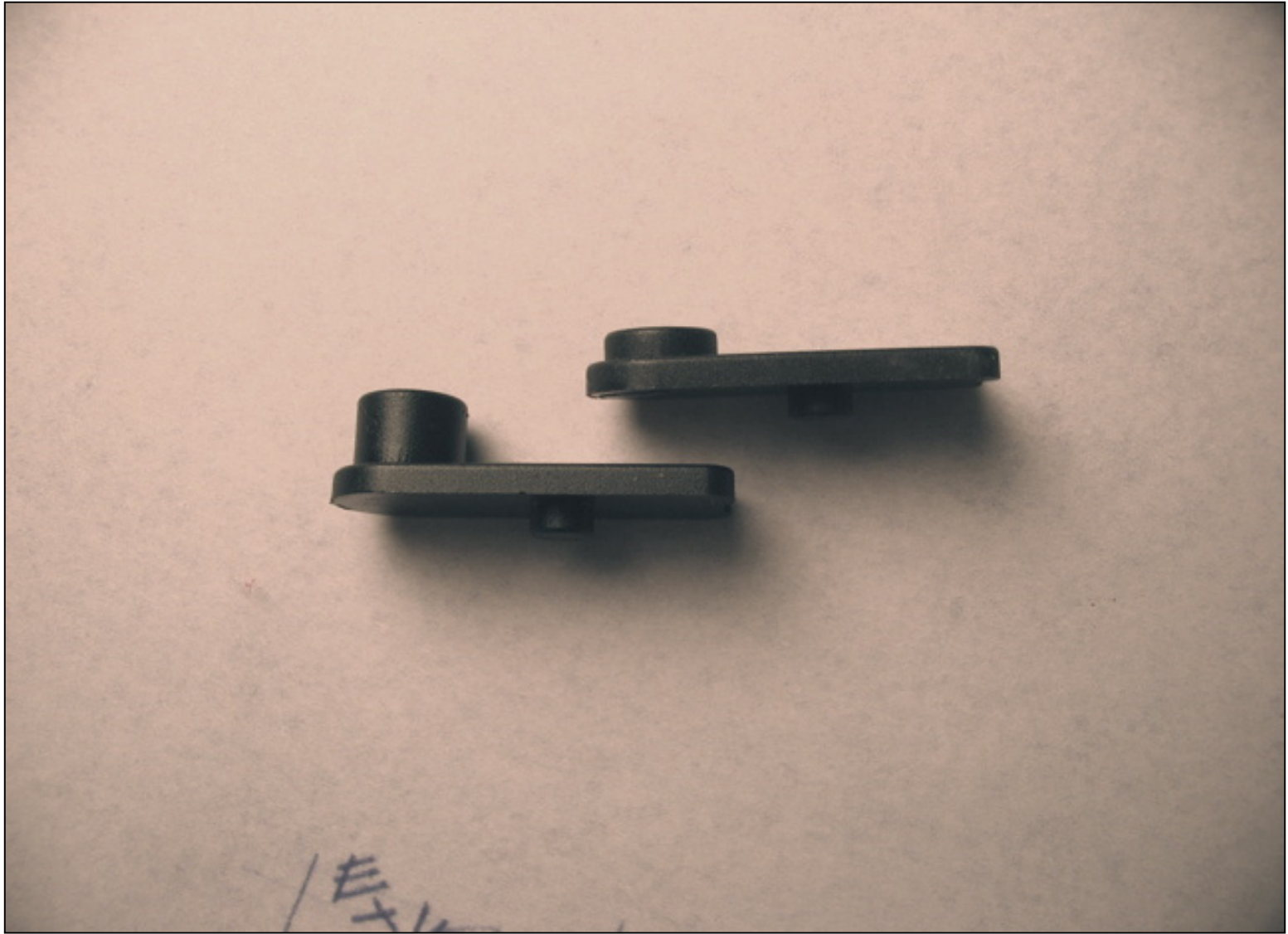

Finally if your new magazine won't comfortably hold 10 rounds you might take a look at lowering the taller spring retaining nub shown on the left as compared to the older models. Why the change? Beats me. I never had any trouble with the old style.

Reassembly:

Clean all grease off the pistol and magazines, spray them down with Birchwood Casey Gunscrubber or similar, blow dry or allow to dry then spray with something like Remington RemOil with Teflon. I blow off any excess with compressed air. I then rub a dry powdered mixture of moly/teflon on the frame grooves and slide rails and on the barrel sleeve. I rub some on the bottom of the breech block and hammer face before reassembly. I also apply a little to the slide ramps where the trigger bar ears hit. I've just started doing this, hadn't thought of it before.

I apply a small amount of blue Threadlocker to the frame screw ends and the barrel nut and tighten them securely. Make sure all oil and grease is removed from the male and female threads or the Threadlocker won't stick. I do this after temporarily reassembling my pistol to check to see that the slide will still cock my newly profiled hammer tip. If it won't I disassemble the pistol and carefully file a very little material off the face of the hammer's cock notch until reliable cocking is achieved. Then I put the screws in with Threadlocker. You are then good to go for at least 27,500 rounds. I clean appx every 500 to 1000 rounds. If I left something out we'll catch it soon. Always release the slide by pulling it back allowing the slide stop to drop then release it. That way you won't wear out the slide catch notch on the slide. Hope this helps. M1911

**Functional Improvements
(MODIFICATIONS)**

**Fix for "Walking" Safety
Lever**

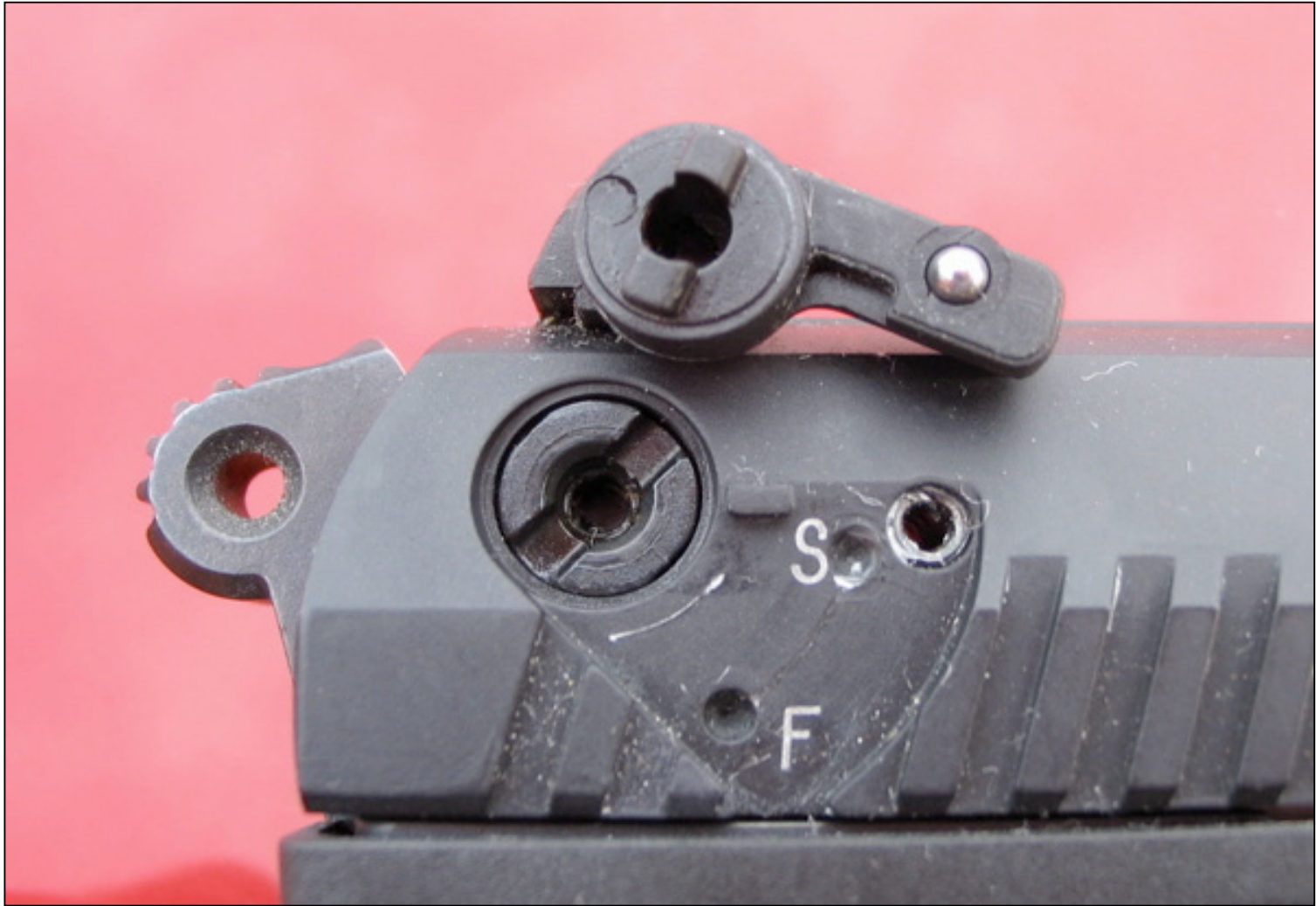

Before you do any modifications make sure that the detents are clean and try tightening both the safety lever screws a bit. That might be all your pistol needs.

If not, make sure the pistol is unloaded, then with the proper sized screwdriver you remove one of the safety levers, do the following work, reinstall it and repeat on the other side. Here the lever has been removed. Note the detent ball that drops in the detent holes. Note the center bar on the safety lever that drops into the receiver inside the slide. This item must not be entirely ground off or the levers won't rotate the safety.



Picture of the safety lever and associated screw.

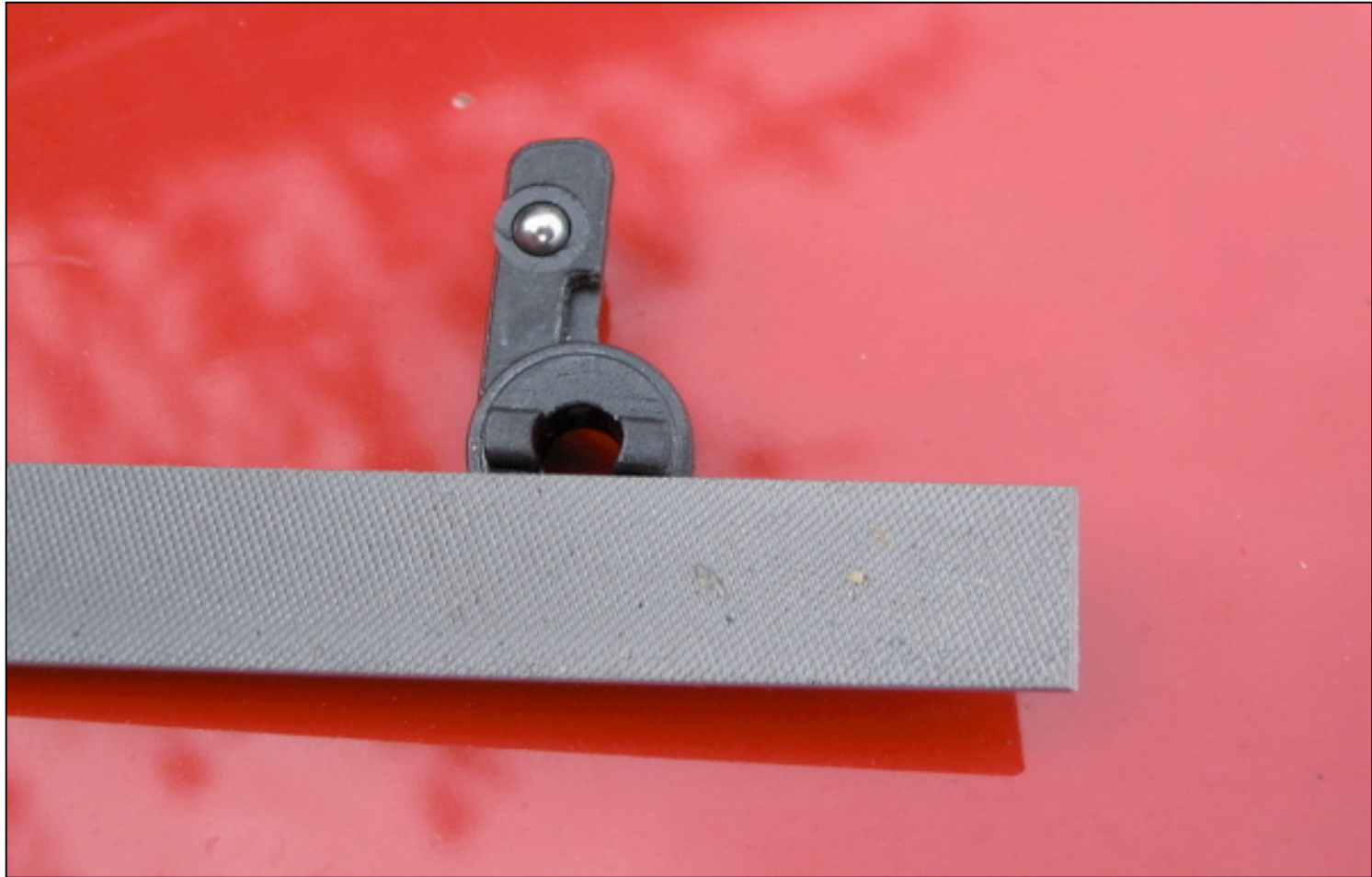

Take a small file or emery paper and lightly file/sand "each" shoulder just a little. Here a small file is resting on one shoulder. Then you lightly file/sand the tip sticking up removing the same amount of material you did from the shoulders. e.g., If you removed 0.005" from the shoulders, remove 0.005" from the center catch. What you are doing is removing just a little material so that the ears will sit a little closer/tighter against the slide. Don't remove so much that the levers themselves begin to drag on the slide nor should that be necessary.

This will cause the detent ball under the safety lever to be pressed tighter against the detent holes firming up movement of the levers. Reinstall the safety lever. Still loose, file a little more. Keep your work neat and square. Don't get carried away, remove a little at a time. You can always take more off, you can't put any back on. Put a little blue Threadlocker on that clean screw once you're good to go and ready for final assembly.

Make sure the screws are tight upon reassembly.

Functional Improvements
(MODIFICATIONS)

Reducing Hammer Drag on
Slide

WARNING

Advanced Skills and
CAUTION required.

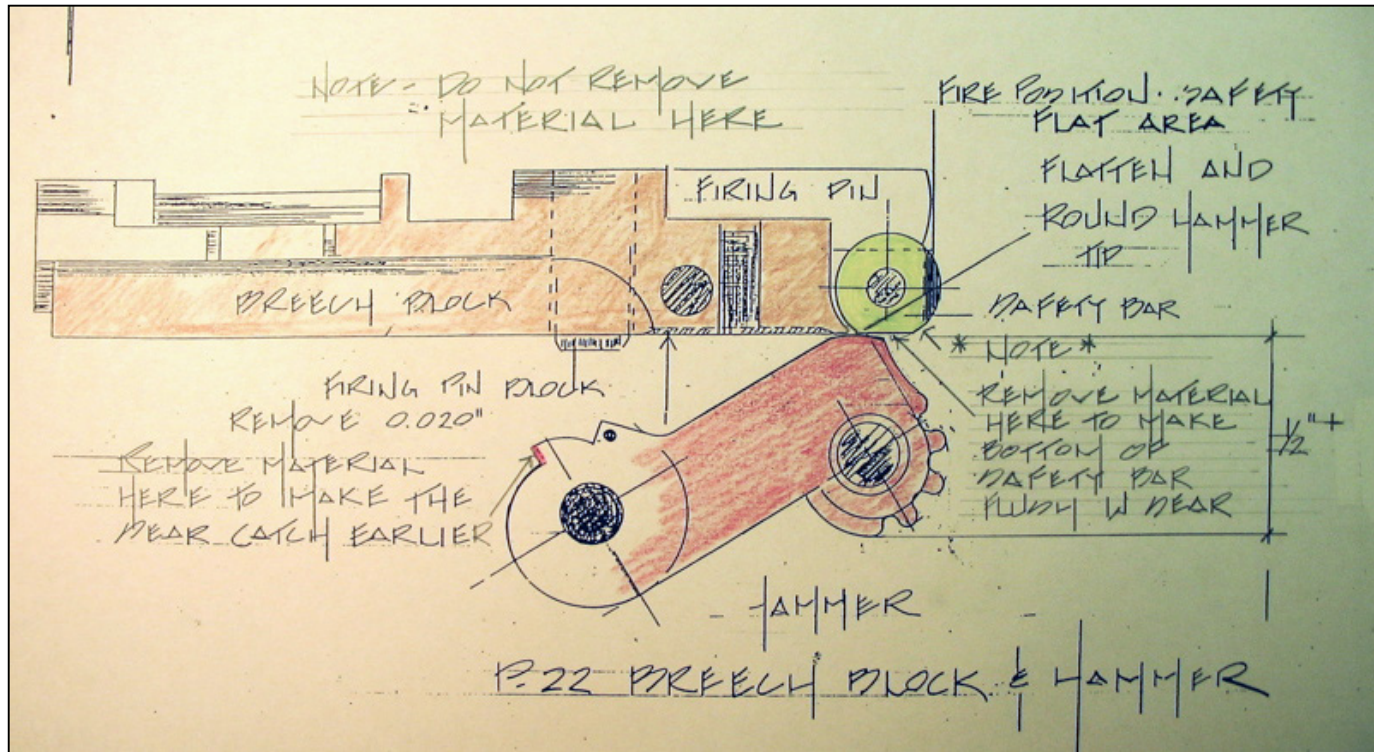

There are several concerns associated with the manner in which the P-22 hammer and breech interface. It is imperative that the relatively low powered .22 cal round be able to cycle the slide which accomplishes several critical operations. Working against the pressure of the slide return spring, friction of the barrel sleeve, the frame rails and grooves, hammer tip dragging on the bottom of the breech block, extract and eject a spent cartridge, cock the hammer and strip a round from the magazine and chamber it for the next shot.

The P-22 has a simple torsion spring that keeps forward pressure on the hammer at all times and especially when being cocked and while cocked. The pressure of the hammer is greatest when it is cocked. The pressure of the cocked hammer against the bottom of the breech block is not relieved simply because the hammer is cocked. In fact it is greatest when the slide is fully rearward, a time when the bearing surfaces between the slide grooves and frame rails is at it's least. I expect 1/4" or less of these components are engaged at this point.

As the slide moves rearward and forward, the hammer tip not only lifts it with considerable force but contributes considerable drag. Nothing can be done about the slide/breech having to expend energy cocking the hammer but I wanted to modify the breech so that as it continues rearward and then forward it was free of most of the hammers drag and uplift. This should provide more energy for other functions and less wear to the critical slide components.

Unload your P-22, remove the slide spring and guide bar, cock the hammer, reinstall the slide, lock the take down, then drag the slide/breech bottom back and forth across the hammer tip and you will see the drag I'm talking about. This mod eliminates it except for the safety bar and that is necessary for cocking. This is also easy to do, just don't remove too much material and weaken the metal where the roll pin goes through. Keep your work square. This is advanced work and not for everyone.

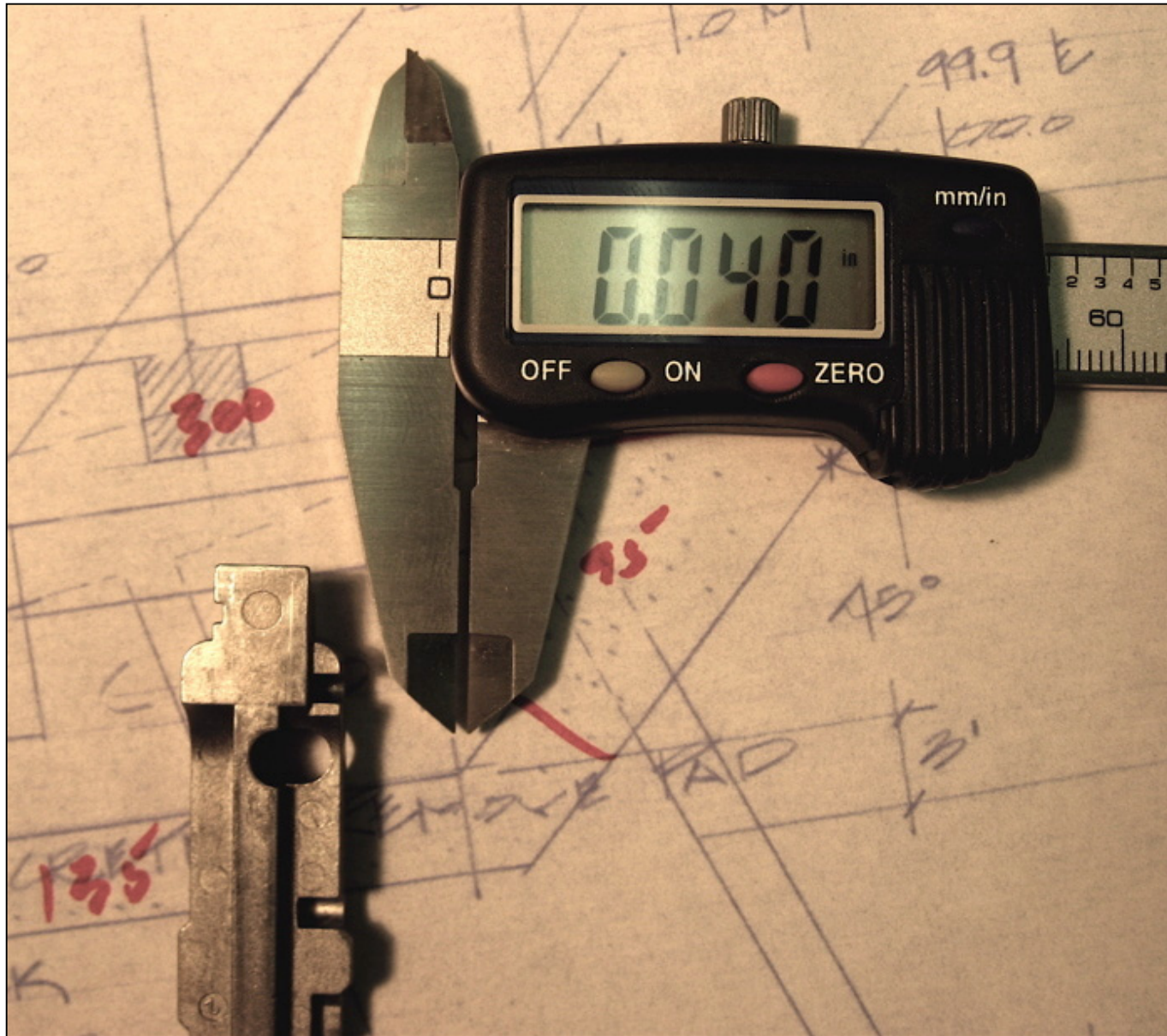

The hammer tip drags across appx. 1/2 inch of the rear of the breech block. The recent test of lubricants indicates that even with the best more than 1 lb of energy is required to pull the breech across the hammer tip here. I had determined by careful measurement that the hammer rebounds appx. 0.020" after being cocked. This allows it to drag on the bottom of the breech block.



There is 0.040 inch of metal between the bottom of the breech block retaining pin hole and bottom of the breech or just enough to remove 0.020 so the hammer tip will no longer drag.

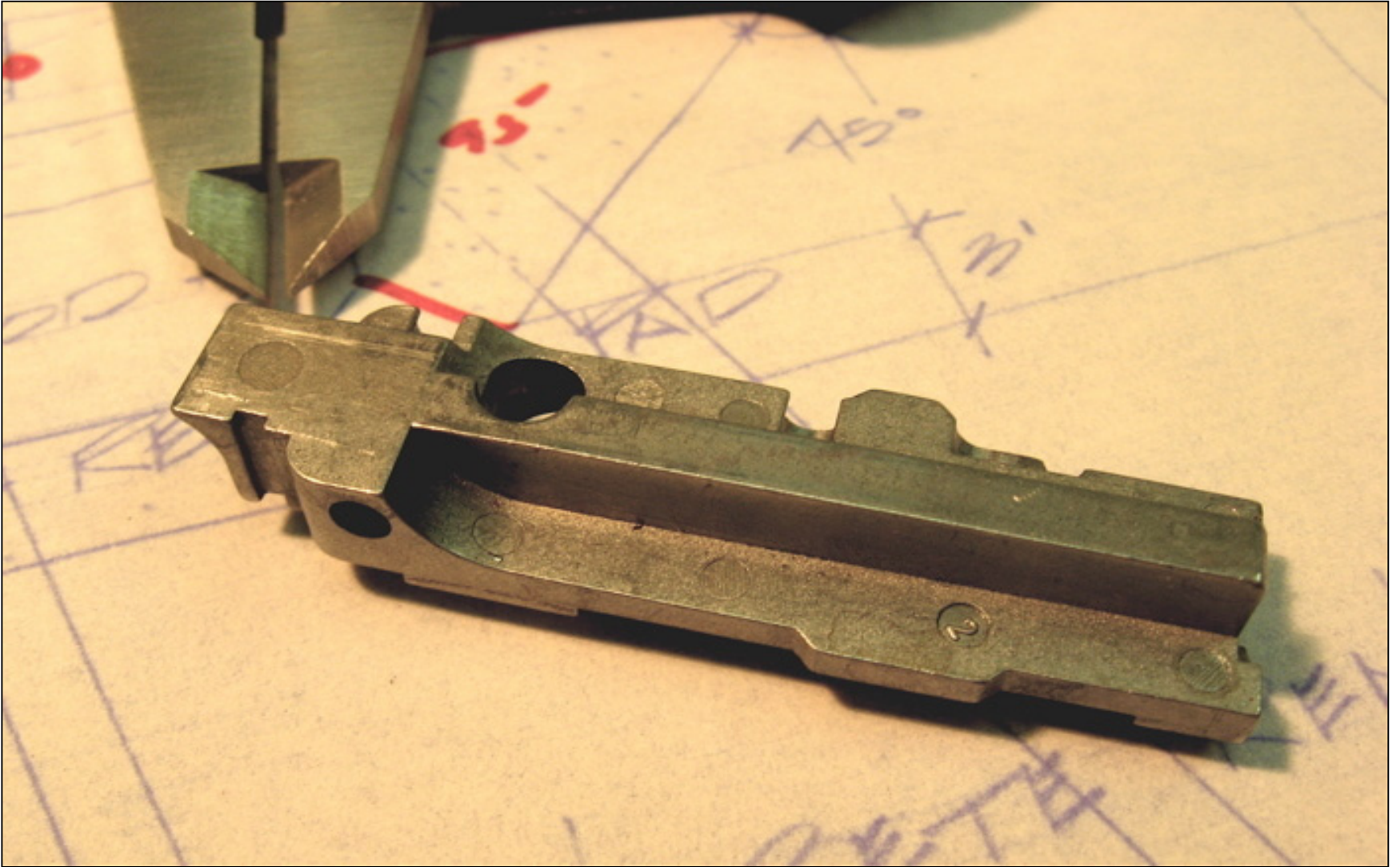

When removing material here I want to leave a ramp at the very rear of the breech to glide the hammer up onto the safety bar and to keep full thickness at the firing pin block.



Having only the finest milling equipment, unlike top Dog, I proceeded in the shop with files and emery paper.



This photo shows the 0.020" of material removed from the bottom rear of the breech block.



This picture shows what my milling effort turned out to look like. The ramp isn't as smooth as could be accomplished with more time and better equipment but the end result is that once the safety bar cocks the hammer the hammer tip does not touch the breech block, especially at the critical very rear position. When the slide moves forward the tip rides over the ramp and roll bar. Friction is almost totally removed except for the brief moment the hammer passes over the safety bar.

I did this to the "test gun" a long time ago so I knew it worked. This is the 0.020" shown in the drawing. I'm not saying do this but it sure frees up the slide and I think helps eliminate slide wear. Drag with any lubricant is now less than 1 oz as the hammer tip doesn't touch.

Part 3

Factory Reference Material



WALTHER P22 BIBLE

1917-1911M

WALTHER

P22
WALTHER

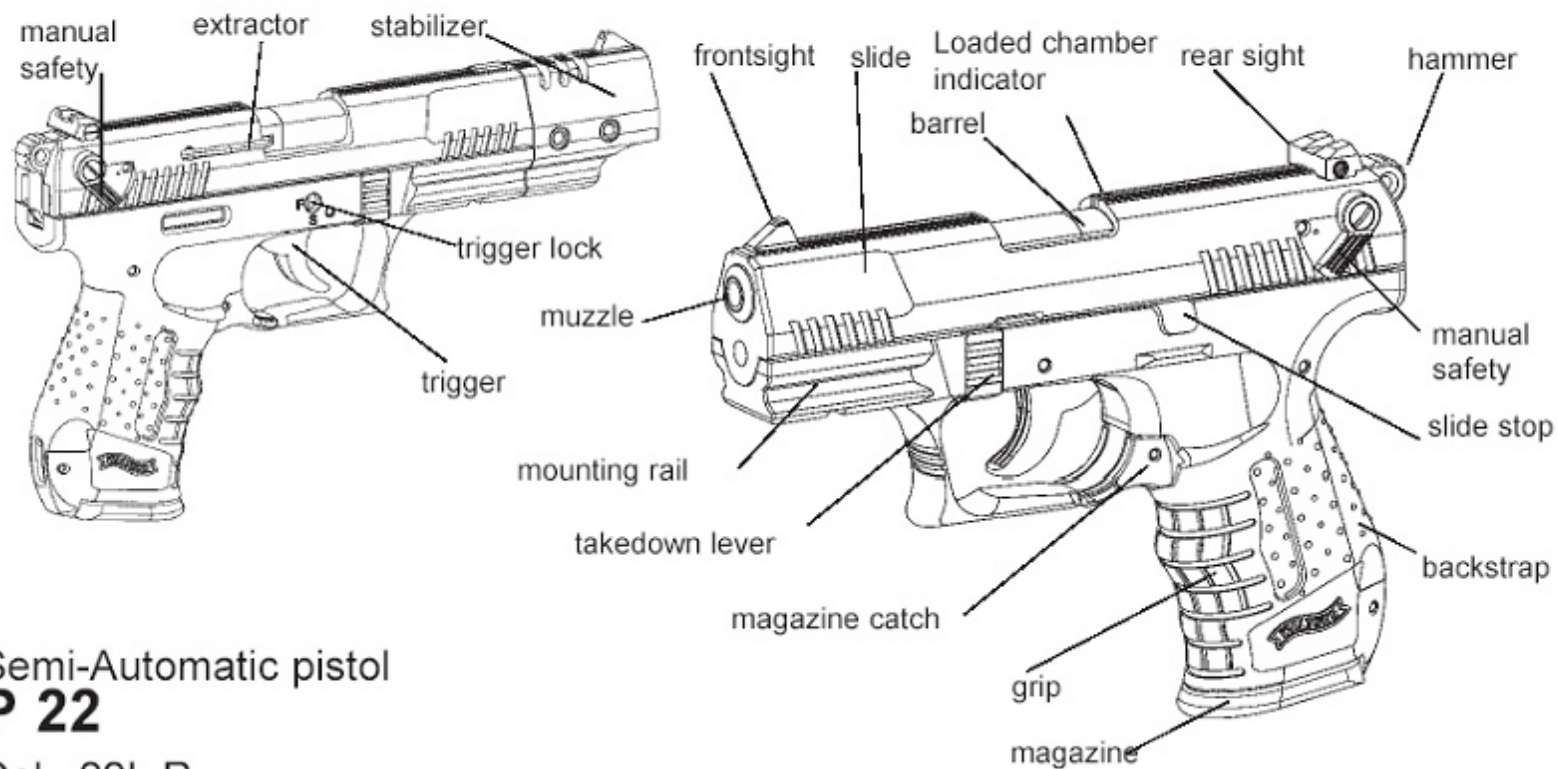

Semi-Automatic pistol
P 22

Cal. .22L.R.

P22

WALTHER

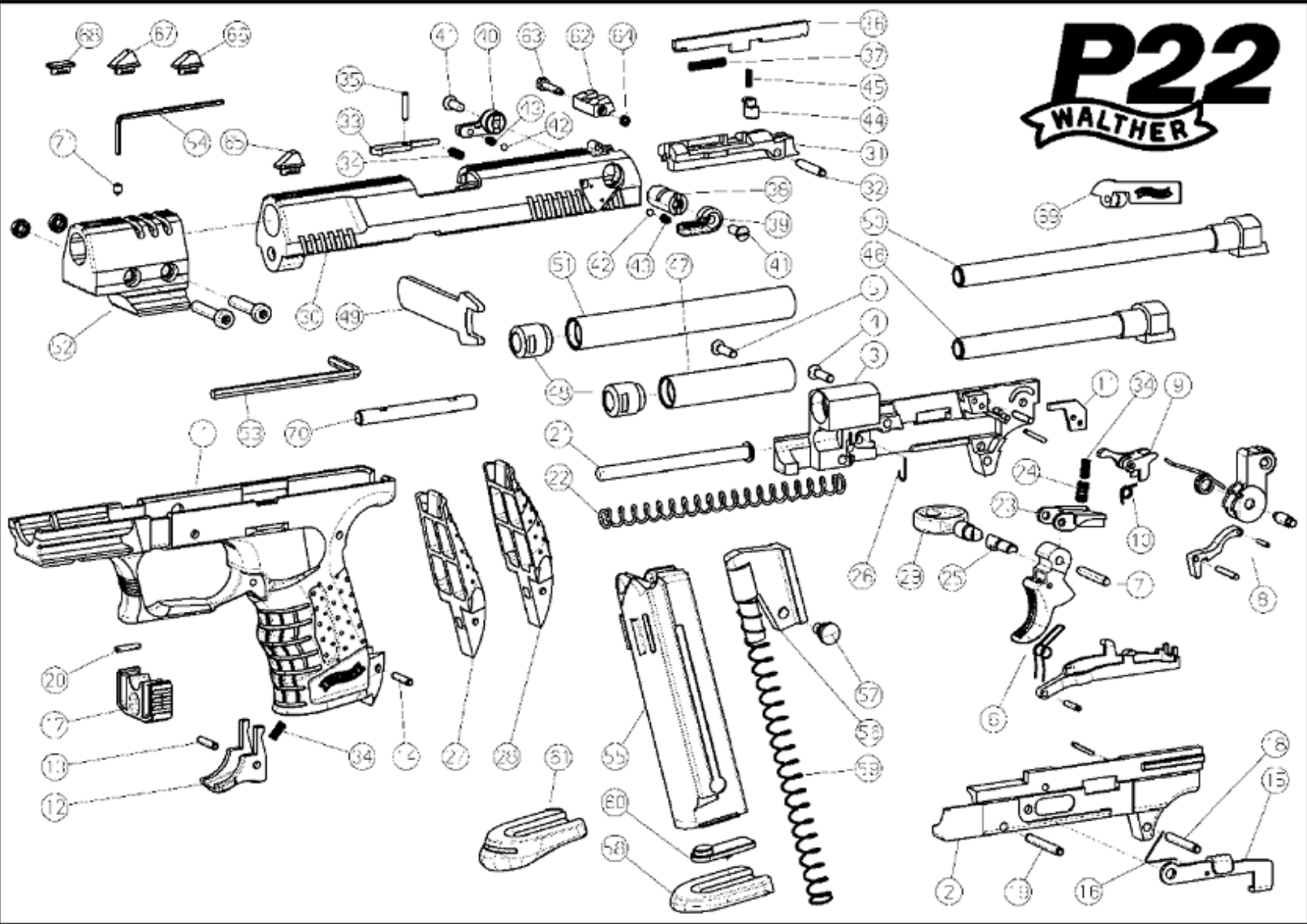

Designation of components

Pos. designation	article no.
1 receiver, polymer	266 04 82
2 sideplate, left	267 04 61
3 sideplate, right	267 04 53
4 stove bolt	266 05 12
5 stove bolt	266 97 22
6 trigger assembly	267 04 37
7 straight pin	266 05 47
8 hammer assembly	267 04 45
9 sear	266 06 44
10 sear spring	266 06 52
11 ejector	266 06 79
12 magazine catch	266 06 95
13 straight pin	266 84 75
14 dowel pin	266 07 17
15 slide stop lever	266 07 25
16 slide stop spring	266 07 33
17 takedown lever	266 07 41
18 dowel pin	266 07 50
19 dowel pin	266 07 68
20 retaining pin	266 07 76
21 spring guidance rod	266 07 84
22 recoil spring	266 89 04
23 magazine safety	266 08 06
24 magazine safety spring	266 08 14
25 trigger lock	266 08 22
26 trigger lock spring	266 08 31
27 backstrap	266 08 49
28 backstrap, large	266 08 57
29 key for trigger lock	266 08 65
30 slide	266 08 73

Pos. designation	article no.
31 breech block	266 08 81
32 dowel pin	266 08 90
33 extractor	266 09 03
34 spring	266 09 11
35 pin	266 09 20
36 firing pin	266 09 38
37 firing pin spring	266 09 46
38 safety block	266 09 54
39 safety lever, left	266 09 62
40 safety lever, right	266 09 71
41 screw	266 09 89
42 ball for safety lever	266 09 97
43 spring for sayfty lever	267 08 10
44 firing pin safety	266 10 04
45 spring	266 10 12
46 barrel 3.4 inch	266 10 47
47 barrel sleeve	266 10 55
48 barrel nut	266 10 63
49 spanner	266 10 71
50 barrel 5 inch	266 10 80
51 barrel sleeve, long	266 10 98
52 stabilizer assembly	267 04 70
53 allen key	218 98 01
54 allen key	266 84 91
55 magazine body	266 11 36
56 follower	266 11 44
57 magazine button	266 11 52
58 magazine butt plate	266 11 61
59 magazine spring	266 11 79
60 butt plate retainer	299 11 87

Pos. designation	article no.
61 magazine butt plate, large	266 12 41
62 rear sight	267 04 88
63 rear sight screw	266 12 68
64 washer	266 12 76
65 front sight 3	267 04 96
66 front sight 2	267 05 00
67 front sight 4	267 05 18
68 filler plug	266 13 14
69 dryfire simulation device	260 83 32
70 mounting pin	266 88 91
71 worm screw	266 84 83